

Microsquirt V3 for Volvo 240 4 Cylinder

INSTALLATION GUIDE AND DIAGRAMS

This main engine harness has been designed for the use of Microsquirt V3 on a Volvo 4 cylinder in a 240.

Microsquirt V3 uses a 35-pin AMPSEAL interface and a sealed case to make a fully sealed unit. This harness uses a matching sealed 35-pin AMPSEAL connector for this union.

SHIELDED WIRES: It's well known that low voltage EFI sensor or ignition signals can be affected by electrical interference (EMI). Megasquirt and Microsquirt are particularly vulnerable. Universal harnesses are available for Microsquirt, however those lack enough shielded wires, unless you add them on your own. This harness was specifically designed with an abundance of high-performance shielding on vulnerable circuits.

Ignition triggering OPTIONS (crank or cam position sensing).

Direct plug-in options for this harness include:

1. DSM CAS (Cam Angle Sensor). This is a custom 24+1 optical CAS (i.e.: Yoshifab), which is adapted to a Volvo distributor bottom half, which you then mount in the normal engine block distributor location. This CAS can plug directly into this harness (using a small adapter sub-harness). It will provide engine timing for Microsquirt. The CAS is used with a distributorless multi-coil ignition.
2. LH 2.4 60-2 flywheel with Volvo crank position sensor. This is the same as a standard Volvo CPS for in an LH 2.4 car. It will provide engine timing for Microsquirt for use with an LH 2.4 ignition distributor coupled with a Bosch ignition amplifier or a distributorless multi-coil ignition.
3. Volvo LH 2.2 Hall sensor style block-mounted distributor. This is a standard ignition distributor from an LH 2.2 240, which can be directly plugged into this harness (using a small adapter sub-harness). The Hall sensor in the distributor provides needed engine timing for Microsquirt and a single factory coil may be used. With this option, there are multiple choices available for ignition amplification, but the preferred choice is a Bosch ignition module.

Other options, such as an EDIS module and 36-1 front crank trigger wheel can be adapted if preferred, but are not available as a direct plug-in with this harness.

LS COILS: An optional available coil sub-harness may be added for a Coil-Near-Plug configuration using four GM LS style coils. This configuration works well with an 8 valve head. LS coils have logic level drivers, which receive trigger signals directly from Microsquirt without need for a separate ignition amplifier. The coils are wired for **Wasted Spark Configuration** using the two Ignition Outputs from the ECU. Pin: IgnOut1 is connected to coils 1 and 4, and Pin: IgnOut2 is connected to coils 2 and 3. When an ignition is configured for Wasted Spark, two coils are fired at once. So in this case coils 1 and 4 will fire together when either cylinder 1 or 4 is ready for spark. Then coil 2 and 3 fire at together when either of those cylinders need spark.

COIL-ON-PLUG: An optional available coil sub-harness may be added to support a Coil-On-Plug configuration using four Denso pencil style coils. This works well with a B234 16 valve head. Since **pencil coils don't have internal drivers**, this configuration requires an optional external ignition amplifier (i.e.: Yoshifab), which is a direct plug-in to this optional sub-harness.

Injector Drivers: Microsquirt V3 has two injector driver outputs. Up to four high-impedance (saturated type) injectors may be used per driver for up to eight injectors. This harness provides connectors for FOUR injectors. The injectors are considered to be Batch Fire, which means all injectors fire at the same time (same as Bosch LH). For this four cylinder harness, each Microsquirt driver output is assigned two injectors. Each driver limits injector current to ~5 amps and will drive **high-impedance injectors** without any changes. If you opt for **low-impedance (peak and hold type) injectors**, they will require the addition of a resistor pack (resistors in series) to limit current. Instructions for building and adding a resistor pack are included in these diagrams.

Map Sensor: Microsquirt V3 has no internal MAP sensor, so an external MAP sensor is required if you will be using a MAP sensor (as in most cases). A good choice is a General Motors type, which may be found with 1, 2, 3 bar, etc. capacity. A 2-bar sensor will support boost up to 14.7 PSI (1 bar over normal atmospheric pressure). This harness uses a General Motors MAP sensor connector for direct plug-in support.

Microsquirt V3 for Volvo 240 4 Cylinder

CUSTOMER DIAGRAMS

Alternator: This main harness incorporates two separate leads for the alternator D+ connection so that you may have your choice of mounting the alternator on the right (normal) side of the engine or on left side (740 style).

MAF Sensor: This main engine harness supports an optional available sub-harness for a MAF sensor, if desired. Microsquirt gives you the choice of using MAP only (most common use), MAF only or MAF/MAP blending. Several MAF sensor types are supported and are detailed in these diagrams.

Idle Valve: This harness provides support for a Bosch 2-wire PWM style idle valve. In order to make room inside the compact Microsquirt case for dual ignition inputs and outputs, stepper motor circuits for a stepper motor idle valve are not included in the ECU case. If a 4-wire stepper motor idle valve is desired, an optional Microsquirt Stepper Adapter Module is available and can be adapted. Those circuits are detailed here also.

No Knock Sensor: Microsquirt V3 will not support a knock sensor directly and knock sensing is not directly supported by this harness. While it's not detailed in this guide, it's possible to adapt or add an external interface module to Microsquirt V3 for a knock sensor if needed.

Embedded Code: Microsquirt V3 comes with preloaded embedded code (unlike Megasquirt -II). You may upgrade to newer code as new versions are released, but you will not have to load the code initially to get Microsquirt running.

Bootloader: The bootloader (laptop interface) function in Microsquirt is externally accessible. Serial RS-232 signals are directed through the 35-pin AMPSEAL connector via an **external 3.5 mm data jack** provided on this harness near the ECU for convenient connection to your computer.

A note about 12v battery power. Power to the Microsquirt ECU will go through a relay block (included with this harness) before going to the ECU. The 12v battery power source to the relays (pin 30) used in this harness should have as direct a path to battery positive as possible. First being switched through the key "ON" circuit. Do not use 12v power from just any 12v source you find in your car. Using dedicated power from the battery to the relay block is the best choice and will provide the cleanest power for the ECU.

Amphenol AT Plugs: This harness uses a number of Amphenol AT sealed plugs. If you are unfamiliar with these, keep in mind they are identical to and 100% interchangeable with Deutsch DT connectors. For more information, a very detailed page has been created about these plugs, which can be found at:

www.240turbo.com/crimps.html#deutsch

Microsquirt controllers are not offered or approved for use on emission controlled vehicles. Check the laws that apply in your location to determine if using Microsquirt is legal for your application.

MicroSquirt V3 for Volvo 4 Cylinder

GENERAL WIRING DIAGRAM

(Wire colors not specific)

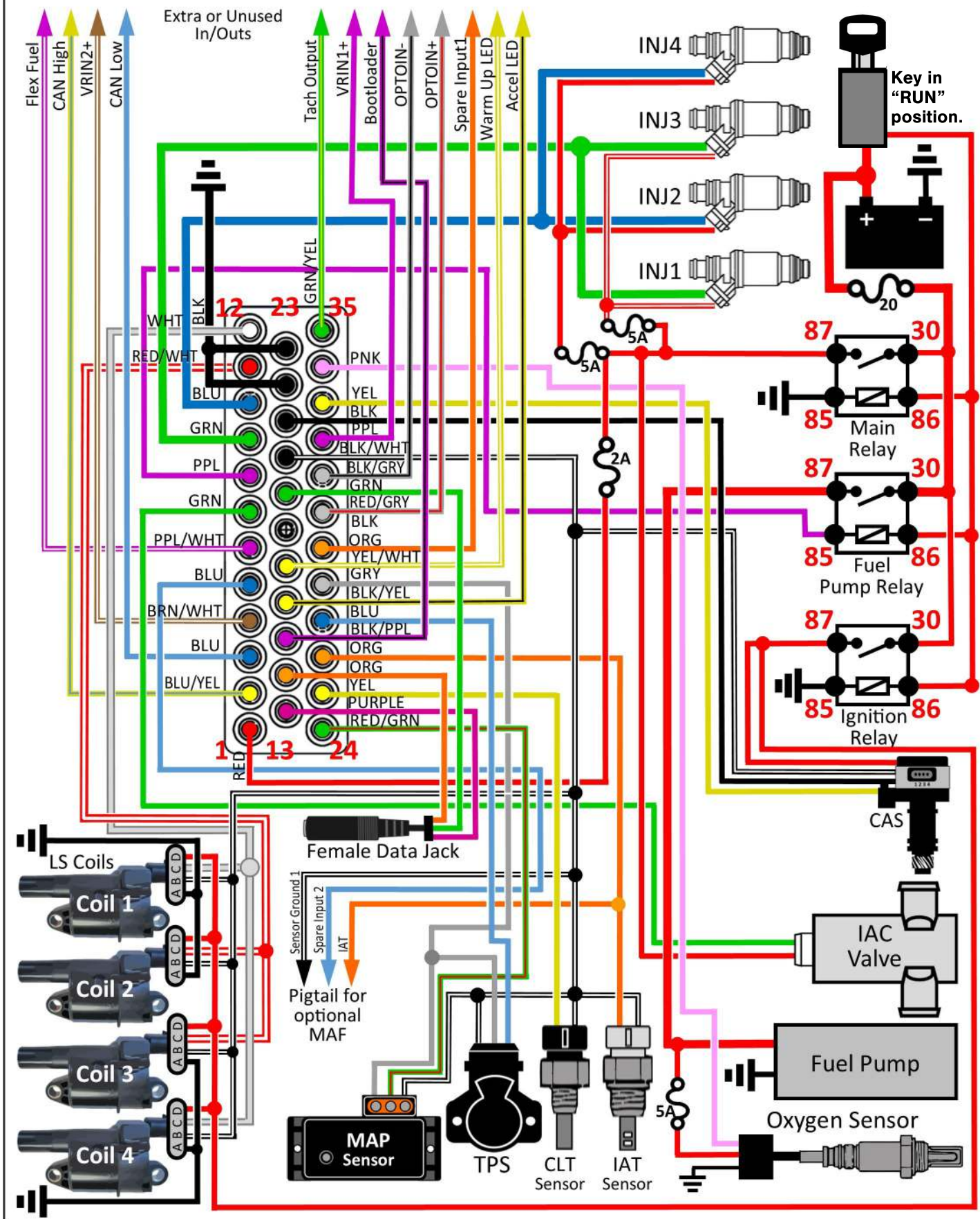

MICROSQUIRT Engine Harness for Volvo 240

MAIN ENGINE WIRING HARNESS VE-5701

Harness Junction Measurements:	
Junc 1 to 2:	4" / 102 mm
Junc 2 to 3:	20" / 508 mm
Junc 3 to Grommet:	6" / 178 mm
Junc 3 to 4:	9" / 229 mm
Junc 4 to 5:	9" / 229 mm
Junc 5 to 6:	9.5" / 241 mm
Junc 6 to 7:	7" / 178 mm
Junc 6 to 8:	4" / 102 mm
Junc 8 to 9:	5.5" / 140 mm

25. 6-Pole Amphenol AT Plug will connect to short resistor harness for your choice of either DSM CAS or LH 2.2 Hall Distributor.

28. OPS Green Wire

29. OPS Black Wire (+Adapter)

24. 1-Pole Coolant Temp

21 a - d.
2-Pole EFI Plugs
x4

23. 2-Pole IAC Valve

26. Alternator B+

Separate B+
cable length
52 inches
(1320 mm).

18. Starter B+

27a. Alternator D+ #1
For Alternator mounted on
right side.

17. 3-Pole
TPS Plug

22. Ground
Ring

20. 2-Pole IAT
Sensor Plug

19. Starter
Solenoid

14. 8-Pole
Female Volvo
Firewall Plug

16. 2-Pole
Coolant Temp
Sensor Plug

15. 3-Pole MAP
Sensor Plug

27b. Alternator D+ #2 for
alternator mounted on left side.

JUNC 6

1. 35-Pole Ampseal
Plug for Microsquir
t ECU

2. 3.5 mm Female Data
Jack.

12. Microsquir
t External
Ground Ring.

JUNC 2

JUNC 5

JUNC 1

JUNC 4

13a & b.
3-Pole Volvo
Crank Position
Sensor and
Ground Ring

11. 6-Pole
Amphenol AT
Ignition Plug

FIREWALL
GROMMET

3. Extra/Unused
ECU Pigtail Wires

Fuses:
4a, 4b & 4c

Micro Relay Plugs:
4. Main Relay
5. Fuel Pump Relay
6. Ignition Relay

JUNC 3

3.5 mm Male Data Jack
Cable with DB9
Interface.

Power Input,
Fuel Pump Relay Output
and Relay Ground

7 & 8. 4-Pole Amphenol AT Plugs.
These allow for in-line
installation of optional injector resistor
pack if needed.

9. 4-Pole Amphenol
AT Plug for Optional
MAF Harness.

AMPSEAL 35-Pin Connector Detail 776164-1 (black) (crimp terminals used: 770854-1)

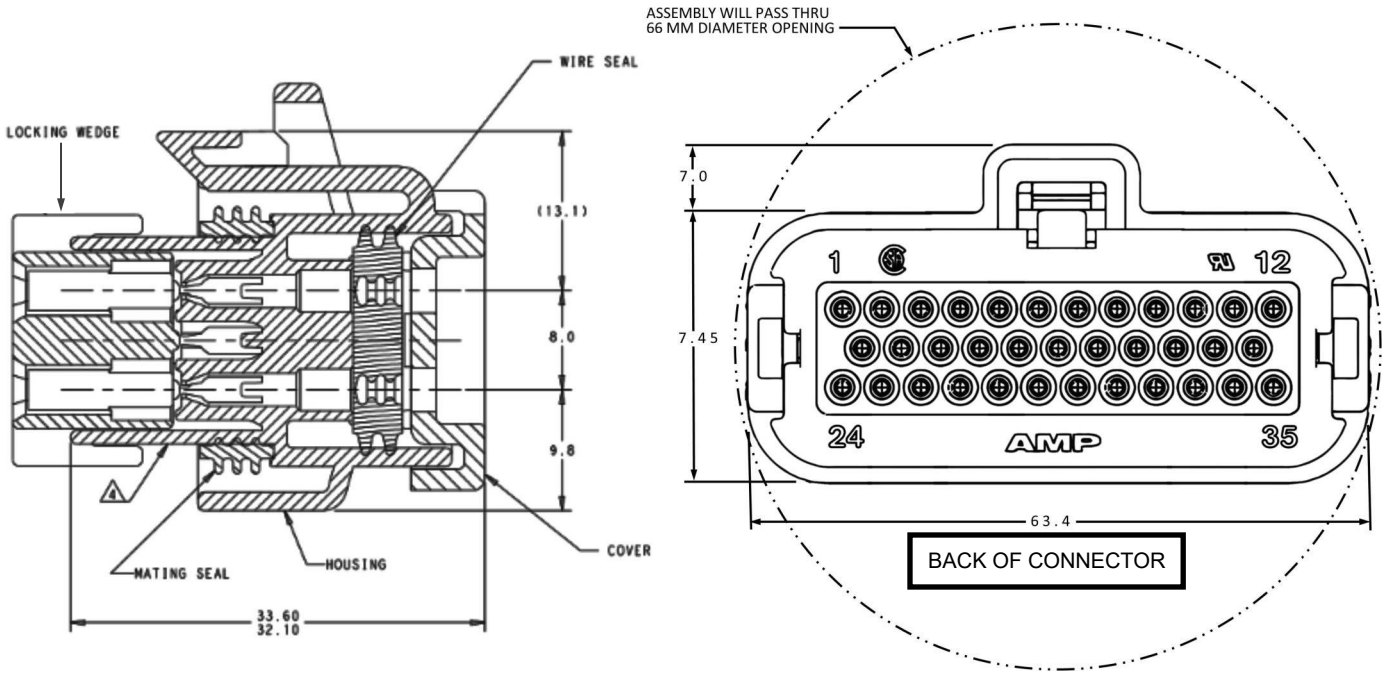

Key slot locations: 6 & 20.

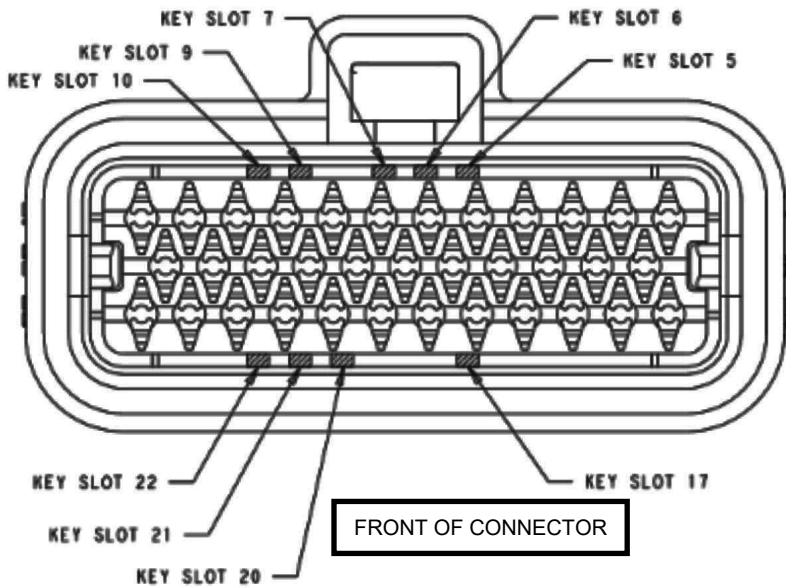

7 & 22	ORANGE	776164-6
5, 10, 22	BLUE	776164-5
9 & 21	GREY	776164-4
7 & 17	NATURAL	776164-2
6 & 20	BLACK	776164-1
KEY SLOT LOCATION (SEE VIEW ABOVE)	COLOR	PART NUMBER

**35-POSITION CONNECTOR
KEY SLOT LOCATIONS**

1

35-Pole Ampseal Connector for Microsquirt ECU

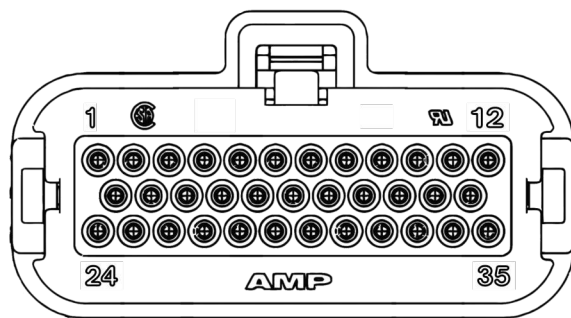

View of REAR of connector

1. Red
2. Blu/Yel
3. Blu/Red
4. Brn/Wht (shielded)
5. Blue
6. Purp/Wht
7. Green
8. Purple
9. Green (fat)
10. Blue (fat)
11. Red/Wht (fat) (shielded)
12. White (fat) (shielded)
13. Purple
14. Orange
15. Blk/Purp
16. Blk/Yel
17. Yel/Wht
18. empty
19. Green
20. Blk/Wht
21. Black (shielded)
22. Black (fat)
23. Black (fat)
24. Red/Grn
25. Yellow
26. Orange
27. Blue
28. Gray
29. Org/Grn
30. Red/Gry
31. Blk/Gry
32. Purple (shielded)
33. Yellow (shielded)
34. Pink
35. Grn/Yel

12v Supply. To 2A fuse and then to Conn. 4 (Main Relay plug), pin 87.

CAN High (not used). 20 cm pigtail exits harness at Junction 2.

CAN Low (not used). 20 cm pigtail exits harness at Junction 2.

VRIN2+ (not used). 20 cm pigtail exits harness at Junction 2.

Spare Input2. To 4-Pole Amphenol AT Conn. 9, pin 4 for MAF pigtail at Junction 3.

Flex Fuel (not used). 20 cm pigtail exits harness at Junction 2.

F-idle/IAC. To Conn. 23 pin 1, 2-Pole EV-1 plug.

Fuel Pump. To Conn. 5 pin 85, fuel pump relay socket. FP Relay Output.

Injector1 (bank 1). To Conn. 7, pins 1 and 3. 4-pole Amphenol AT plug.

Injector 2 (bank 2). To Conn. 7, pins 2 and 4. 4-pole Amphenol AT plug.

Ignition Output2. To Conn. 11, pin 3. 6-pole Amphenol AT plug at Junction 4.

Ignition Output1. To Conn. 11, pin 4. 6-pole Amphenol AT plug at Junction 4.

Serial Rx. To Conn. 2, ring. Female 3.5 mm data jack.

Serial Tx. To Conn. 2, tip. Female 3.5 mm data jack.

Bootloader. Wire pigtail. 20 cm from Junction 2.

Accel LED (not used). 20 cm pigtail exits harness at Junction 2.

Warm Up LED. Not used. 20 cm pigtail exits harness at Junction 2.

Empty. Not used.

Serial Ground. To Conn. 2, sleeve. Female 3.5 mm data jack.

Sensor GROUND (return). To Conn. 9, pin 1; Conn. 11, pins 2 & 5; Conn 17, pin 1; Conn. 25, pin 1.

VRIN2- (ground). To Conn. 25, pin 4. 6-pole Amphenol AT plug.

Ground (external). To Conn. 12, external ground ring for Microsquirt ECU.

(Same as above) To Conn. 12, external ground ring for Microsquirt ECU.

MAP. To Conn. 15, pin B, 3-pole MAP sensor.

CLT. To Conn. 16, pin A, 2-pole coolant temp sensor.

IAT (intake air temp). To Conn. 9, pin 2, 4-pole Amphenol AT plug at Junction 3 (optional **MAF**).

To Conn. 20, pin A, **IAT** (intake air temp) sensor.

TPS. To Conn. 17, pin 3, TPS sense (return signal from Throttle Position Sensor).

5+ Vref (voltage out to sensor). To Conn. 15, pin C, 3-pole MAP sensor.

To Conn. 17, pin 2, (voltage out to TPS).

To Conn. 25, pin 5, 6-pole Amphenol AT plug.

Spare Input 1 (not used). 20 cm pigtail exits harness at Junction 2.

OPTOIN+ (not used). 20 cm pigtail exits harness at Junction 2.

OPTOIN- (not used). 20 cm pigtail exits harness at Junction 2.

VRIN1+ (input). To Conn. 13, pin 2, Volvo VR Crank Position Sensor.

VRIN1- (input). To Conn. 13, pin 1, Volvo VR Crank Position Sensor.

To Conn. 25, pin 3, 6-pole Amphenol AT plug.

O2 (input). Wire pigtail. 20 cm from Junction 2. For Input from wide band O2 module.

Tach Output. Wire pigtail. 20 cm from Junction 2.

2

3.5 mm Female Data Jack for DB9 Computer Interface Cable.

Data jack is 4 inches (102 mm) from 35-pole connector.

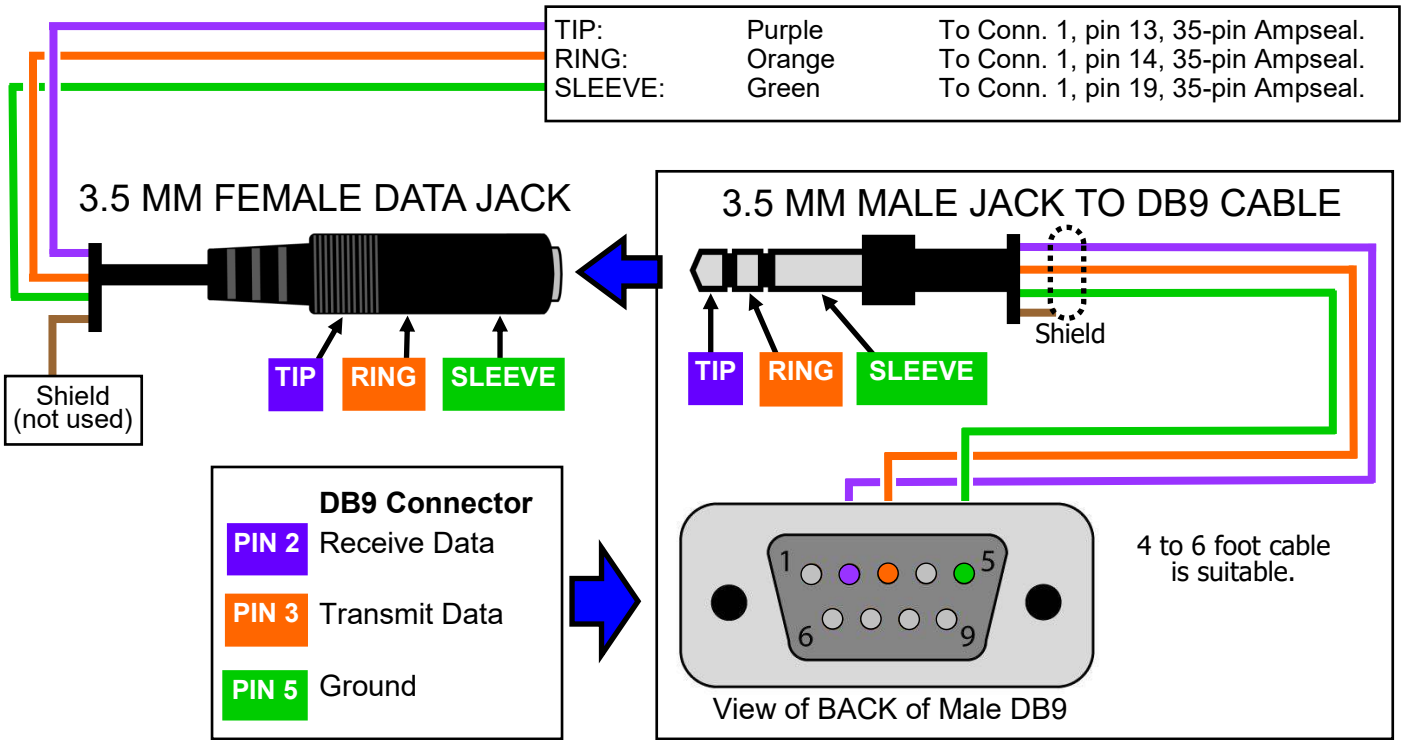

3

Unused and Extra Wire Pigtails

Provided for additional, optional or future hookups as needed.

ECU#	COLOR	FUNCTION	TO ECU LOCATION
2.	Blu/Yel	Unused CAN High	To Conn. 1, pin 2.
3.	Blu/Red	Unused CAN Low	To Conn. 1, pin 3.
4.	Brn/Wht (Shielded)	Unused VRIN2+	To Conn. 1, pin 4.
5.	Blue	Extra Spare Input 2	To Conn. 1, pin 5.
6.	Purp/Wht	Unused Flex Fuel	To Conn. 1, pin 6.
15.	Blk/Purp	Bootloader wire	To Conn. 1, pin 15.
16.	Blk/Yel	Unused Accel LED	To Conn. 1, pin 16.
17.	Yel/Wht	Unused Warm Up LED	To Conn. 1, pin 17.
20.	Blk/Wht	Extra Sensor Ground/Return	To Conn. 1, pin 20.
28.	Gray	Extra Vref 5v	To Conn. 1, pin 28.
29.	Org/Grn	Unused Spare Input 1	To Conn. 1, pin 29.
30.	Red/Gray	Unused OPTOIN+	To Conn. 1, pin 30.
31.	Blk/Gray	Unused OPTOIN-	To Conn. 1, pin 31.
34.	Pink	O2 Input from wide band	To Conn. 1, pin 34.
35.	Grn/Yel	Tach Output	To Conn. 1, pin 35.

RELAY AND FUSE BANK

LITTLEFUSE PART NUMBERS

Littlefuse 03540532Z Fuse Block
 Littlefuse 03540541Z Mounting Stud
 Littlefuse 913-053 Relay Terminal Small
 Littlefuse 913-772 Fuse Terminal

Littlefuse 03540507Z Relay Block
 Littlefuse 03540523Z Connecting Wedge
 Littlefuse 913-067 Relay Terminal Large

- 4** You will need to choose a 12 volt Automotive Micro Relay with two 1/4 inch (6.3 mm) and three 3/16 inch (4.8 mm) pins. 15A or higher capacity is recommended. The Main Relay provides power to the Microsquirt ECU. Terminal part numbers for this relay-fuse bank if replacement terminals are needed: Littlefuse 913-053, 913-067 and 913-772.

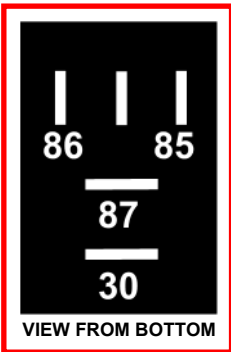
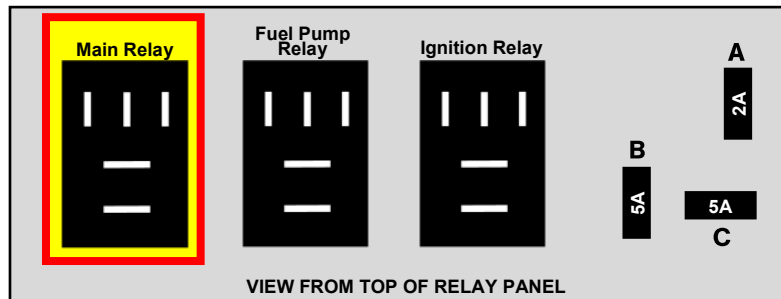

30. Red	To Conn. 5, 6, pin 30.	*To 12v battery. Main power wire is common with pin 30 on all three relays.
85. Black	To Conn. 6, pin 85.	To chassis ground 6b.
86. Red	To Conn. 5, 6, pin 86.	To 12v switched power. This circuit should have power when the key is in the “run” and “start” positions. Wire is common to pin 86 on all three relay plugs.
87. Red	To Fuse 4a (2 amps)	For system power to Microsquirt ECU (Conn. 1, pin 1).
	To Fuse 4b (5 amps)	For power to injectors 1 and 3 (to Conn. 21a, pin 2 and Conn. 21c, pin 2).
	To Fuse 4c (5 amps)	For power to injectors 2 and 4 (to Conn. 21b, pin 2 and Conn. 21d, pin 2).
87a.	To Conn. 23, pin 2	For PWM IAC Valve power.
	Not used	

***MAIN POWER FUSE NOTE:** 12v battery positive wire: A **20A fuse is recommended** to be installed in this circuit between the battery and this relay/fuse bank.

- 4a** **4b** **4c**

Fuses for Main Relay Output

MICRO Fuses for Main Relay output to ECU and Fuel Injectors.

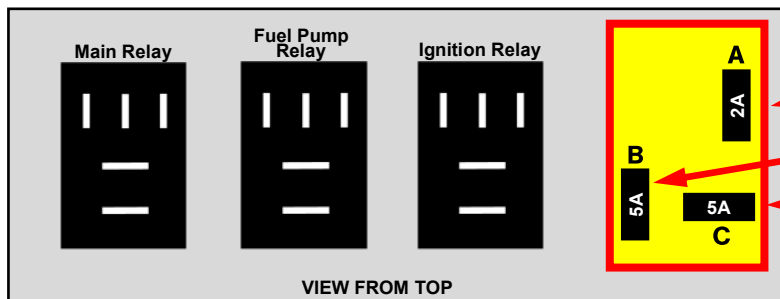

- 4a. 2 Amps (ECU)
- 4b. 5 Amps (Inj. 1 & 3)
- 4c. 5 Amps (Inj. 2 & 4)

4a. Red	To Microsquirt ECU (Conn. 1, pin 1).
4b. Red/White	To injectors 1 and 3 (Conn. 21a, pin 2 and Conn. 21c, pin 2).
4c. Red/Black	To injectors 2 and 4 (to Conn. 21b, pin 2 and Conn. 21d, pin 2).

RELAYS/FUSES (Continued)

5

Fuel Pump Relay

Choose a 12 volt Automotive Micro Relay with two 1/4 inch (6.3 mm) and three 3/16 inch (4.8 mm) pins. 15A or higher capacity. This relay provides power to the Fuel Pump(s).

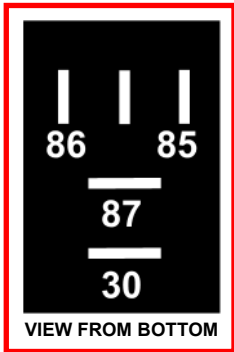
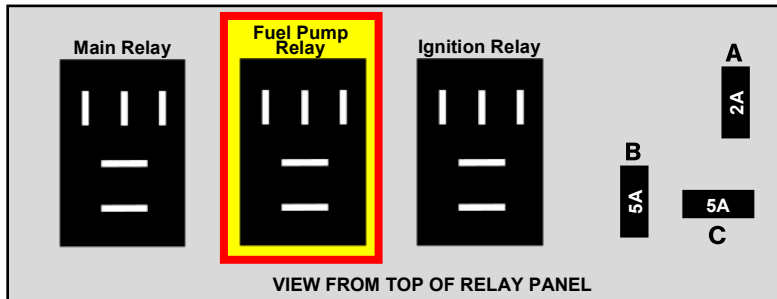

- | | | |
|-----------|-------------------------|--|
| 30. Red | To Conn. 4, 6, pin 30. | To battery positive 12v. Wire is common with pin 30 on all three relay plugs. |
| 85. Black | To Conn. 1, pin 8. | To fuel pump relay output GROUND at ECU pin 8. |
| 86. Red | To Conn. 4, 6, pin 86. | To 12v switched power. This circuit should have power when the key is in the “run” and “start” positions. Wire is common to pin 86 on all three relay plugs. |
| 87. Red | Wire pigtail OUT | Used for 12v power OUTPUT to fuel pump(s). |
| 87a. | Not used | |

6

Ignition Relay

Choose a 12 volt Automotive Micro Relay with two 1/4 inch (6.3 mm) and three 3/16 inch (4.8 mm) pins. 15A or higher capacity. This relay provides power to Ignition.

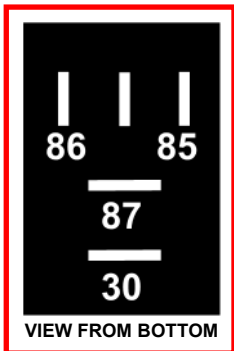
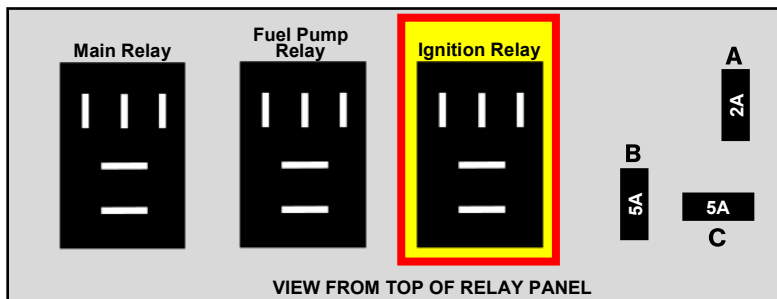



- | | | |
|-----------|------------------------|--|
| 30. Red | To Conn. 5, 6, pin 30. | To battery positive 12v. Wire is common with pin 30 on all three relay plugs. |
| 85. Black | To Conn. 6, pin 85. | To chassis ground 6b. |
| 86. Red | To Conn. 5, 6, pin 86. | To 12v switched power. This circuit should have power when the key is in the “run” and “start” positions. Wire is common to pin 86 on all three relay plugs. |
| 87. Red | To Conn. 25, pin 2. | 12v power for optional CAS. Not used for other options at Conn. 25. |
| | To Conn. 11, pin 6. | 12v power for coil options. |
| 87a. | Not used | |

MICROSQUIRT Engine Harness for 240

RELAYS/FUSES (Continued)

6b

Relay Block Power Connections (Red wire pigtails, inputs/outputs)

- | | | | |
|---|--------|--------------|--|
|  | 1. Red | 12v Battery | This is intended to be connected to direct battery power. A fuse may be placed between the battery and fuse block. |
|  | 2. Red | 12v Switched | Connected to power switched ON when the key is in the "RUN" position. |
|  | 3. Red | 12v Output | This is power output to the fuel pump circuit. |

Relay Block Ground Connection

8 mm ground ring with 2 wires (ground wires from Main Relay and Ignition Relay).
Intended for ground to chassis under dash near relay bank.
Length of this lead: about 10 inches (254 mm).



- | | |
|----------|----------------------------|
| 1. Black | To Conn. 4, pin 85. Relay. |
| 2. Black | To Conn. 6, pin 85. Relay. |

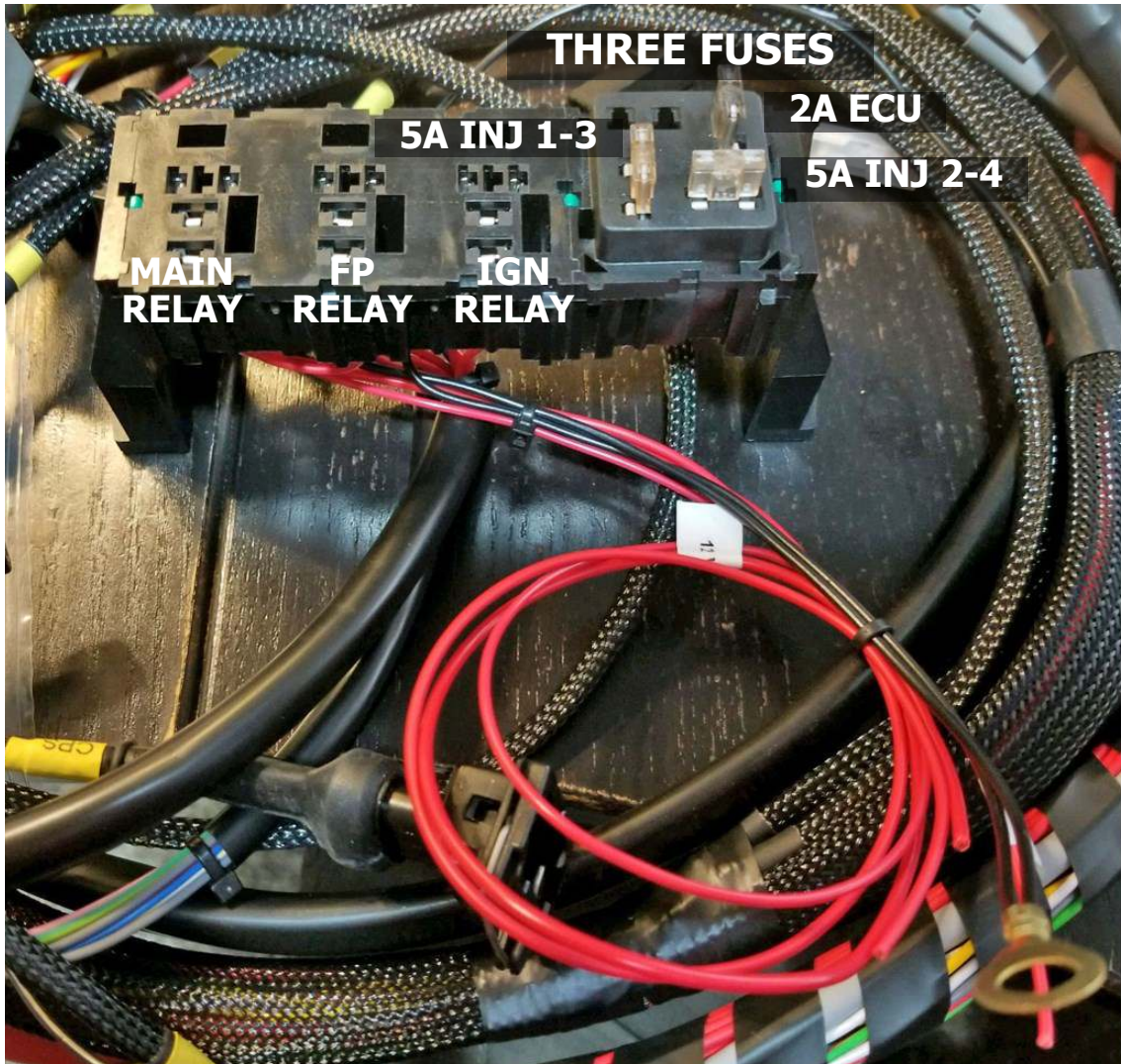

Amphenol AT (or Deutsch) Sealed Connector Detail

Amphenol Part Numbers listed below for 2-Pole, 4-Pole and 6-Pole Connectors.

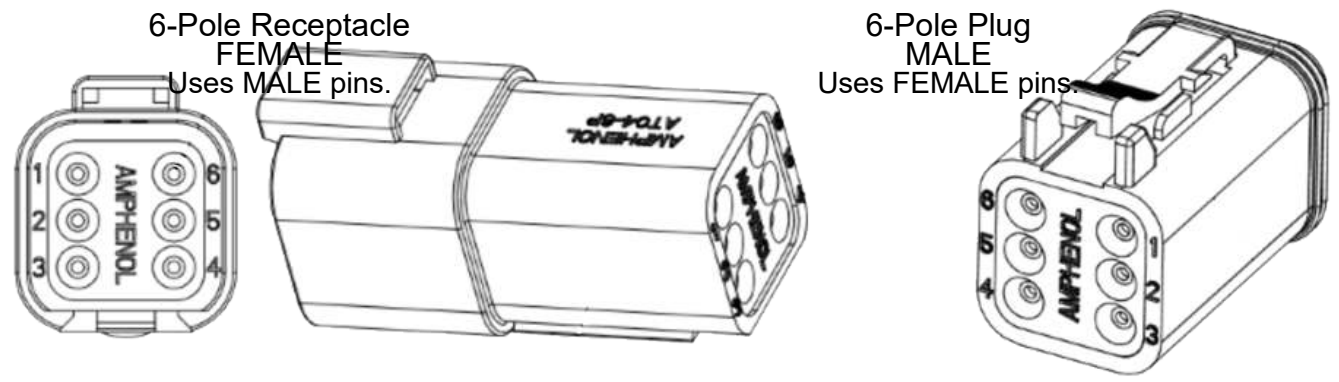
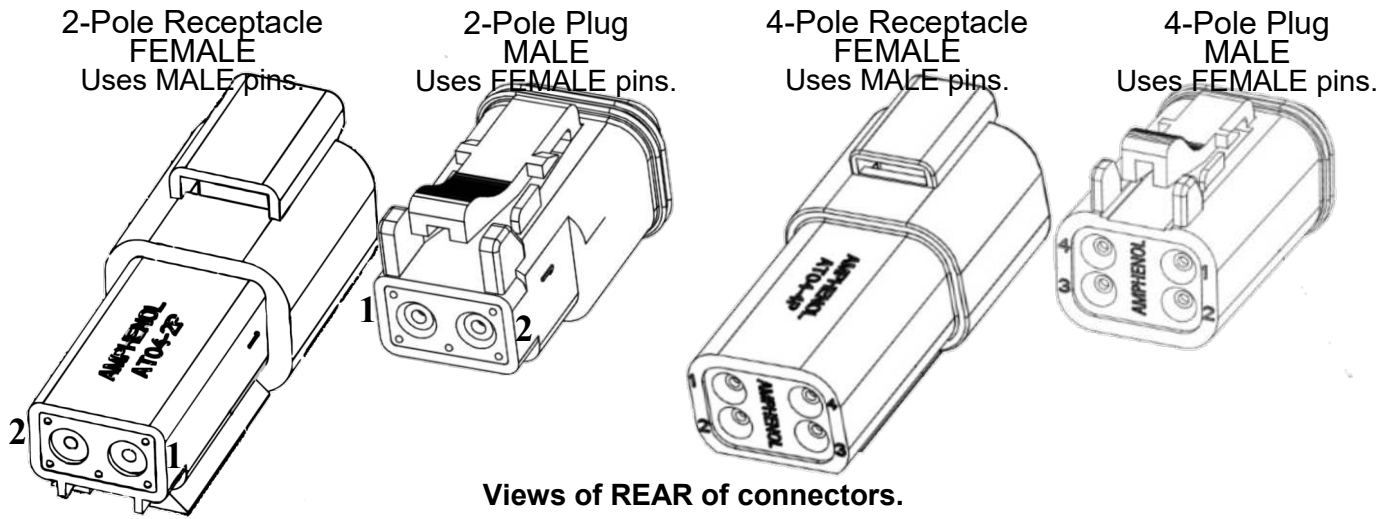
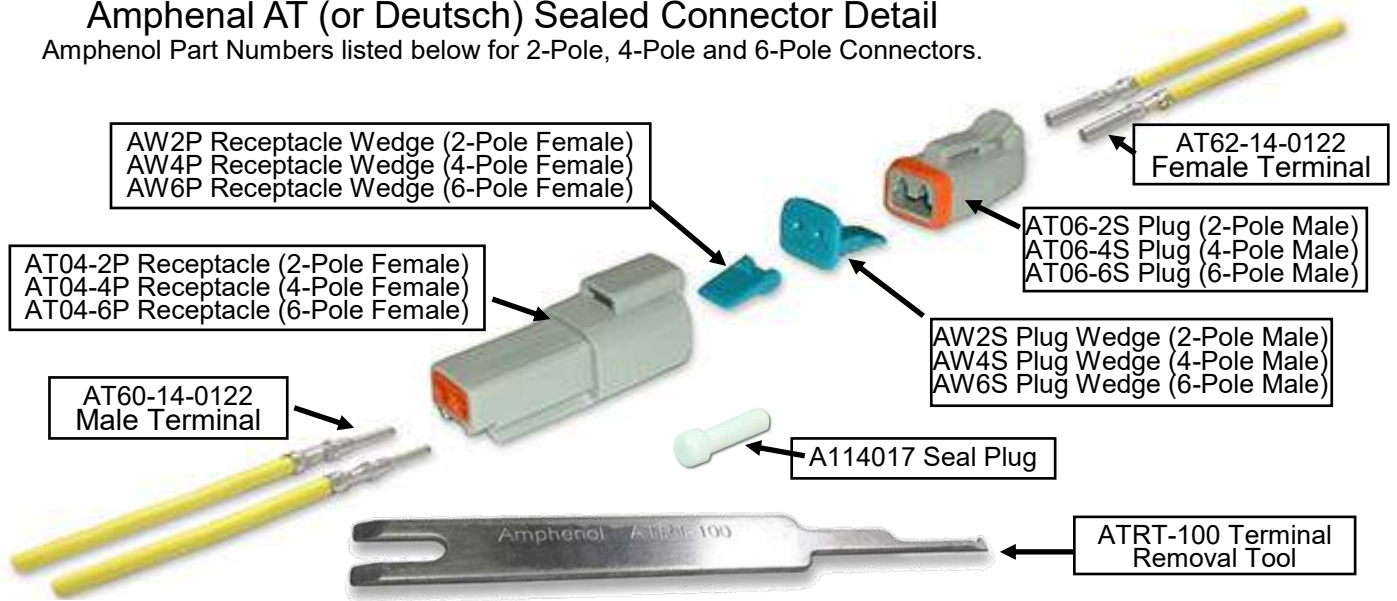

Amp Rating for Amphenol AT: **10A** (using 18 gauge wire)

NOTE: Amphenol AT Series connectors and parts are all 100% compatible with Deutsch DT Series connectors.

FUEL INJECTOR CONNECTOR UNDER DASH

7

Conn 7. 4-Pole Amphenol AT Plug under dash. Fuel Injector Circuits.

Plugs 7 and 8 are found on the main harness (under dash near grommet). These may be disconnected and an optional fuel injector resistor pack may be installed between them (details below).

Wire lead is a short distance from Junction 3.

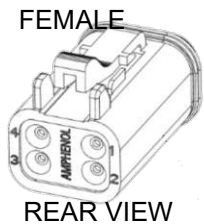

PLUG 7 DETAIL

1. Green	To Conn. 1, pin 9	35-pole Ampseal.
2. Blue	To Conn. 1, pin 10	35-pole Ampseal.
3. Green	To Conn. 1, pin 9	35-pole Ampseal.
4. Blue	To Conn. 1, pin 10	35-pole Ampseal.

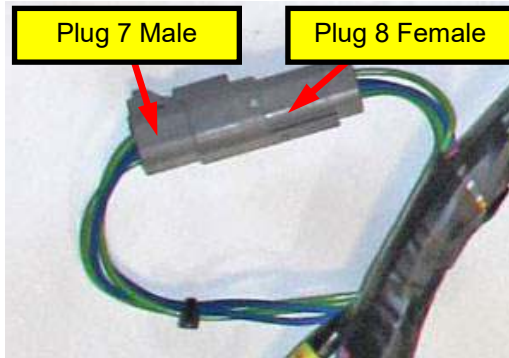

8

Conn 8. 4-Pole Amphenol AT Receptacle under dash. Fuel Injectors

Wire lead is a short distance from Junction 3.



PLUG 8 DETAIL

1. Green	To Conn. 21a, pin 1	Fuel Injector plug 21a, pin 1 (Cyl 1).
2. Blue	To Conn. 21b, pin 1	Fuel Injector plug 21b, pin 1 (Cyl 2).
3. Green	To Conn. 21c, pin 1	Fuel Injector plug 21c, pin 1 (Cyl 3).
4. Blue	To Conn. 21d, pin 1	Fuel Injector plug 21d, pin 1 (Cyl 4).

Image below shows construction of a simple optional resistor pack harness. Four resistors (typically 20-25 watt) are needed, each wired in series for use with low-impedance (peak and hold type) injectors.

If needed, there is info for calculating specific resistor Ohm value at:

<http://www.useasydocs.com/details/inject.htm>

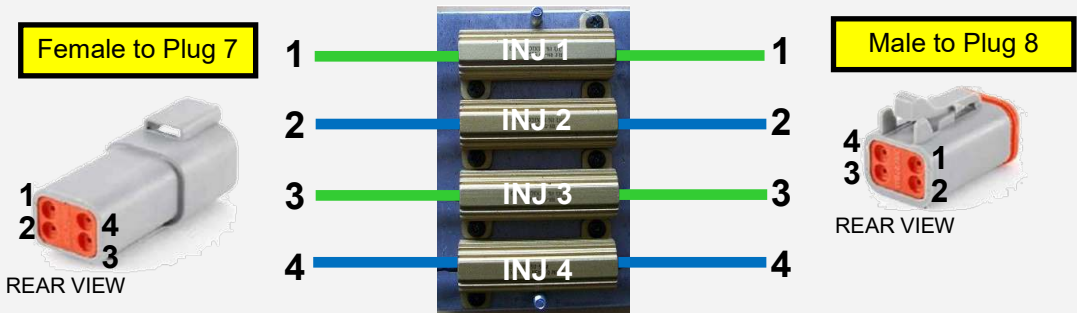

MAF (Optional)

9

4-Pole Amphenol AT Plug

This plug is found on the main harness. It is available for use if an Optional MAF Sensor will be installed. Wire lead should be 2 inches (51 mm) from Junction 3. May be SHIELDED or TWISTED WIRES.



MALE PLUG
(Female Pins)

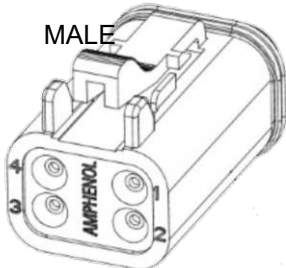

REAR VIEW

1. Blk/Wht	To Conn. 1, pin 20	35-pole Ampseal. Sensor Ground Return.
2. Orange	To Conn. 1, pin 26	35-pole Ampseal. IAT input.
3. Black (shield)	This wire is not connected to a ground in the main harness. If a MAF harness is connected, then this wire is then grounded to the engine or near the MAF in that harness.	
4. Blue	To Conn 1, pin 5	35-pole Ampseal. Spare Input 2.

10

OPTIONAL MAF HARNESS (not included)

4-Pole Amphenol AT Plug with Pigtail.

For Optional MAF Sensor.

Wire lead pigtail: Approx. 64 inches (162 cm).

May be SHIELDED or TWISTED WIRES.



FEMALE RECEPTACLE
(Male Pins)

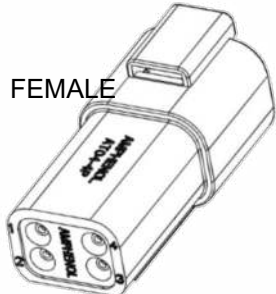

REAR VIEW

1. Blk/Wht	To Conn. 1, pin 20	Shielded or twisted pigtail 64 inches.
2. Orange	To Conn. 1, pin 26	Shielded or twisted pigtail 64 inches.
3. Black (shield)	This wire is to be connected to ground at the MAF end. It may be connected to an engine ground or a ground near the MAF.	
4. Blue	To Conn 1, pin 5	Shielded or twisted pigtail 64 inches.

PHOTO NOT AVAILABLE

OPTIONAL SUGGESTED MAF SENSORS

MAF Sensor signal wires should be shielded, but may be twisted if shielding is not possible. Shield should be grounded near MAF.

From ECU 26, IAT. Not used on a typical 3-Pin or 4-Pin MAF. Only used on a 6-Pin MAF using its own INTERNAL IAT sensor. In this case an EXTERNAL IAT Sensor would not be used.

From ECU 20, Sensor Ground.

From ECU 5, Spare Input 2.

Example MAF #1: 3-Pin Infinity Q45 90 mm PN 22680-61U00

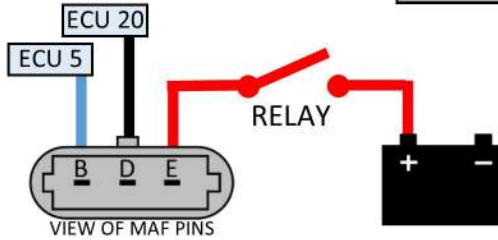

An adapter can be found for any of these MAFs so a hose can be attached to both ends.



Example MAF #2: 4-Pin Ford Racing SVT/Lightning 90 mm PN M-12579-L54

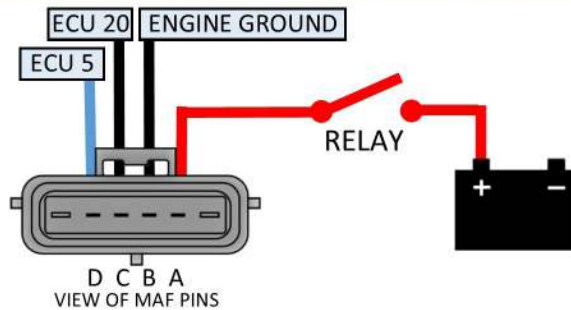

NOTE: Uses a 6-Pin Connector, but only uses 4 pins.



Example MAF #3: 6-Pin Ford, Internal IAT Sensor (unknown size)

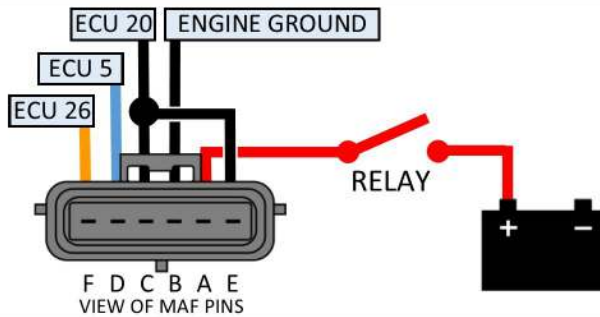

Example MAF #4: Nissan N62 (Z32) 80 mm PN 22680-30P00

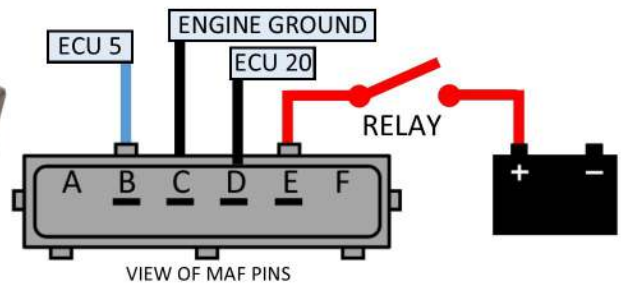

COIL OPTIONS

11

Detail for 6-Pole Amphenol AT Plug

This plug is found on the main harness under the hood near the firewall grommet. It is used for an optional IGNITION sub-harness from those listed below.

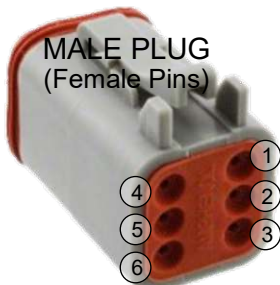

MALE PLUG
(Female Pins)

REAR VIEW

VE-5710 LS Coil Harness

VE-5729 COP (Coil on Plug) plus Ignition Module Harness

VE-5715 Bosch Ignition Module Harness, using a single coil (see page 39).

Wire lead should be 8 inches (204 mm) from Junction 3.

1.	—	not used	
2.	Blk/Wht	To Conn. 1, pin 20	35-pole Ampseal. Sensor Ground Return.
3.	Red/Wht	To Conn. 1, pin 11	35-pole Ampseal. Ignition Output 2.
4.	White	To Conn 1, pin 12	35-pole Ampseal. Ignition Output 1.
5.	Blk/Wht	To Conn. 1, pin 20	35-pole Ampseal. Sensor Ground Return.
6.	Red	To Conn. 6, pin 87	Ignition Relay Plug 12v.

VE-5710 LS Coil Harness

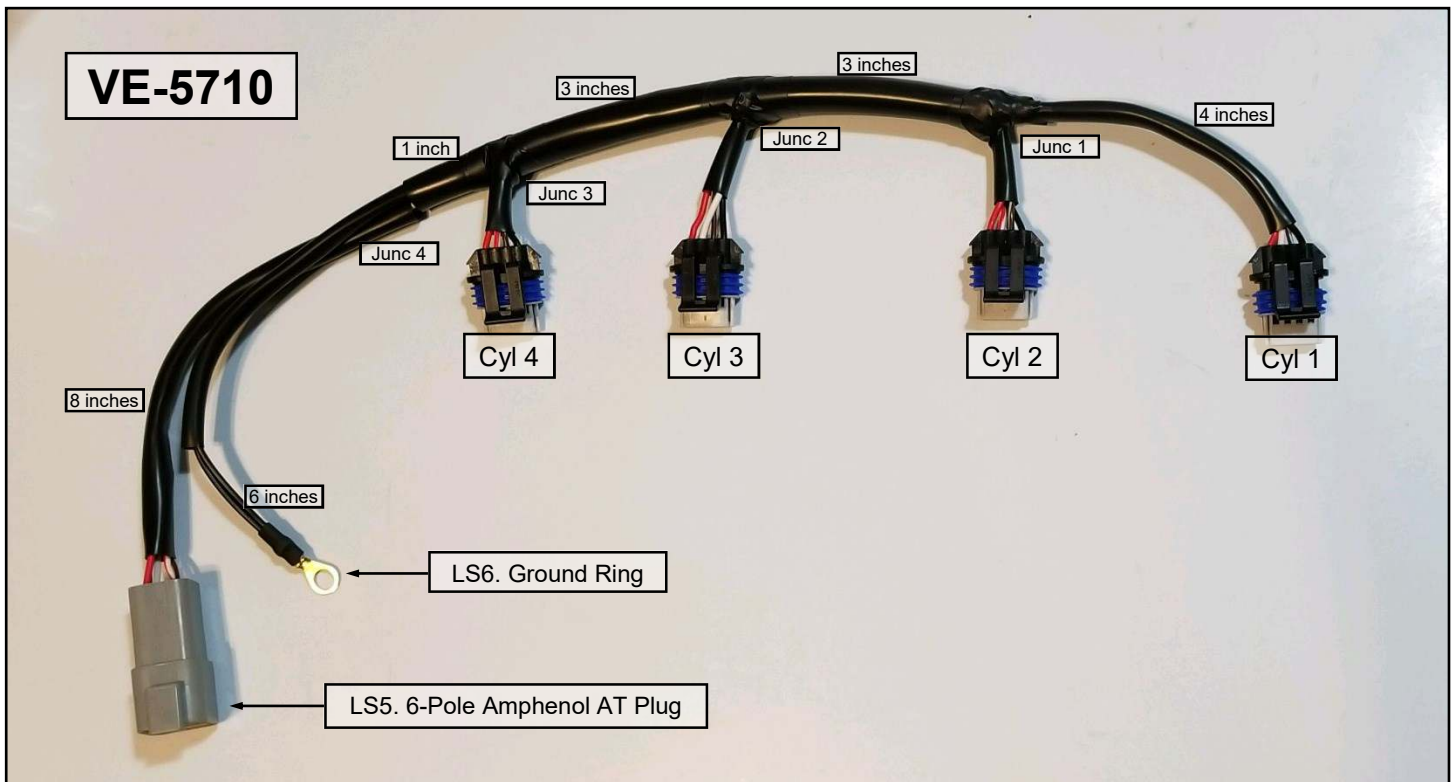

Optional Sub-Harness VE-5710 LS Four Coil Harness (cont.)

This sub-harness uses GM LS style coils, which have built-in igniters and may receive **logic level** signals directly from the TWO Microsquirt ignition outputs. No external ignition amplifier is needed when using this coil configuration.

Many ignition modules (AKA "igniters") and some coils with built-in igniters (such as the LS coil) require a **logic level** signal for operation. Generally this means a 0 or 5 volt signal is received at the coil signal pin. This 0 or 5 volt signal alternates at appropriate times to activate DWELL and SPARK.

Most logic level coils, including an LS coil, work in a positive logic mode. When 5v is received to the coil signal pin, the coil begins to charge (DWELL). Then when the signal alternates to 0 volts, the coil fires (SPARK).

The FIRING ORDER for a 4 cylinder engine is **1-3-4-2**. Here we have four logic level Delco (GM) D514a coils wired to TWO ignition outputs. They're configured to fire in order, which means: COIL 1, then COIL 3, then COIL 4, then COIL 2.

To accomplish this using only TWO ignition outputs, the outputs alternate:

- First **IGN OUTPUT1** fires **COIL 1**.
- Then **IGN OUTPUT2** fires **COIL 3**.
- Then **IGN OUTPUT1** fires **COIL 4**.
- Then **IGN OUTPUT2** fires **COIL 2**.

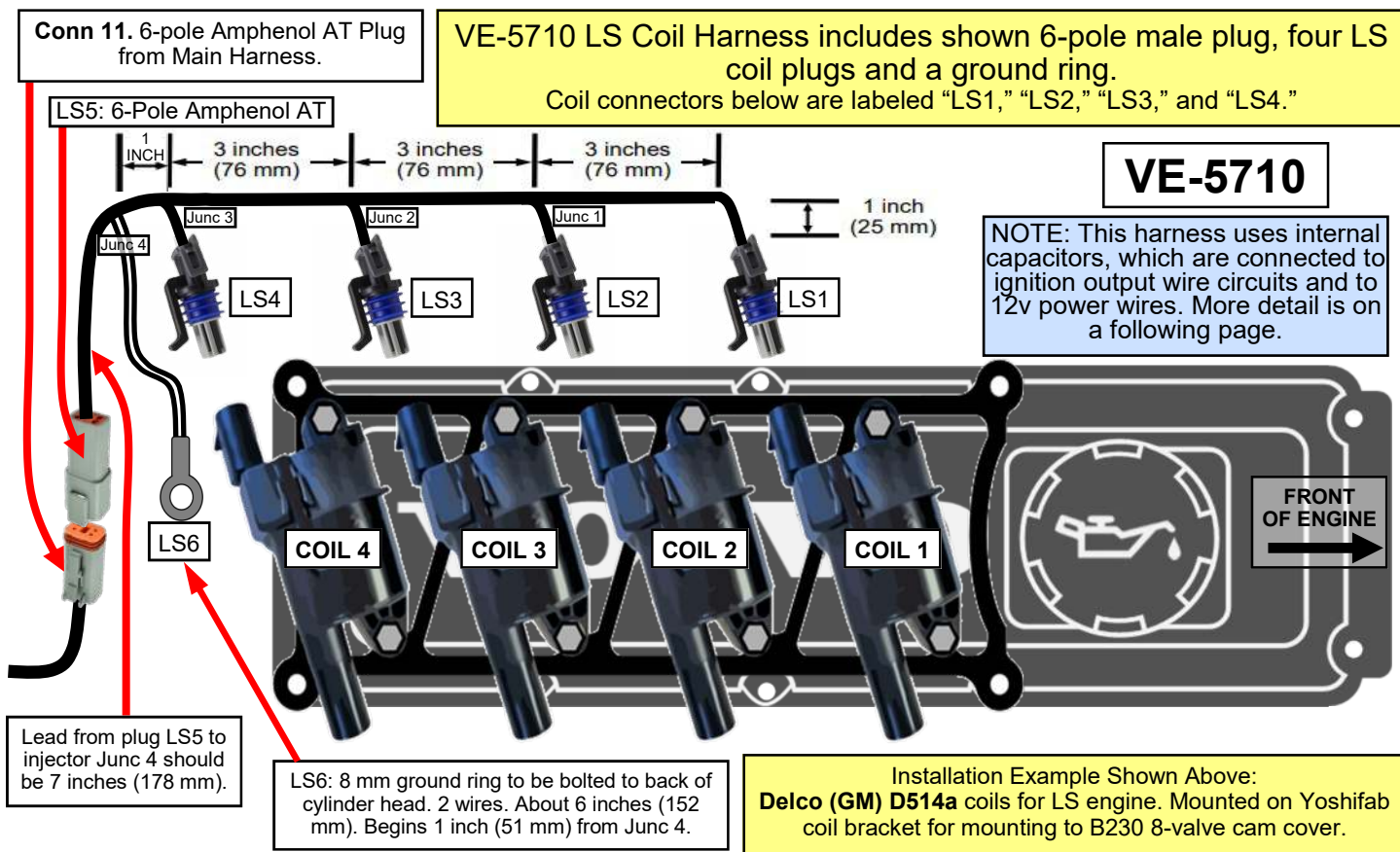

Lead from plug LS5 to injector Junc 4 should be 7 inches (178 mm).

LS6: 8 mm ground ring to be bolted to back of cylinder head. 2 wires. About 6 inches (152 mm). Begins 1 inch (51 mm) from Junc 4.

Installation Example Shown Above:
Delco (GM) D514a coils for LS engine. Mounted on Yoshifab coil bracket for mounting to B230 8-valve cam cover.

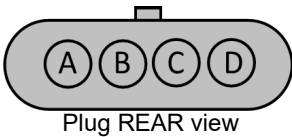

Detail for 4-Pole Coil Connectors for **Coils 1 and 4**

- A. Black
- B. Blk/Wht (shielded)
- C. White (shielded)
- D. Red

- Ground to engine ground ring.
- To 6-Pole LS5 pin 5 (Gnd Sensor Return).
- To 6-Pole LS5 pin 4 (Ignition Output 1).
- To 6-Pole LS5 pin 6 (12v switched).

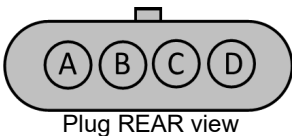

Detail for 4-Pole Coil Connectors for **Coils 2 and 3**

- A. Black
- B. Blk/Wht (shielded)
- C. Red/Wht (shielded)
- D. Red

- Ground to engine ground ring.
- To 6-Pole LS5 pin 5 (Gnd Sensor Return).
- To 6-Pole LS5 pin 3 (Ignition Output 2).
- To 6-Pole LS5 pin 6 (12v switched).

Optional Sub-Harness VE-5710 LS Four Coil Harness (cont.)

FEMALE RECEPTACLE (Male Pins)



Plug REAR view

1. — not used
2. Blk/Wht
3. Red/Wht
4. White
5. Blk/Wht
6. Red

Detail for 6-Pole Amphenol AT Connector LS5
All wires except for power wires are Shielded between ECU and Coils

- To coil plug pin B at LS2 and LS3 (Gnd Sensor Return).
- To coil plug pin C at Connector LS2 and LS3 (Ign Output 2).
- To coil plug pin C at Connector LS1 and LS4 (Ign Output 1).
- To coil plug pin B at LS1 and LS4 (Gnd Sensor Return).
- To coil plug pin D at ALL FOUR connectors (12v switched).

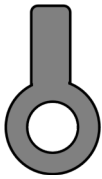

Two wires:
Black
Black

8 mm Ground Ring P7
Bolted to engine ground location at back of cylinder head.
Shields are connected to local coil engine grounds.

- To 4-Pole Coil Connectors LS1 and LS2, pin A.
- To 4-Pole Coil Connectors LS3 and LS4, pin A.

EXAMPLE OF TYPICAL LS COIL PLUG CAPACITOR DETAIL

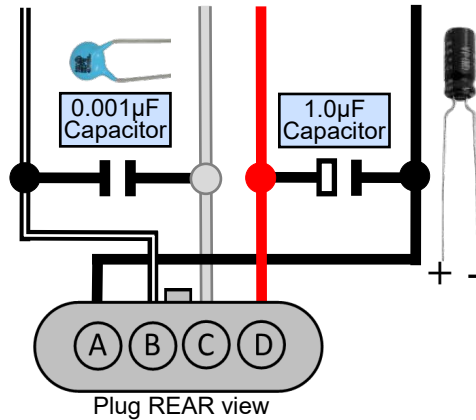

Plug REAR view

NOTE: Capacitors must be installed with correct polarity. The negative side always points toward ground. Positive side points toward power.

Coil Near Plug using GM LS coils WIRING DIAGRAM

These circuits allow you to incorporate four LS style coils which may be used for a Coil Near Plug (CNP) setup on an 8 valve or 16 valve head. Coils depicted below are **Delco D514a (PN 12573190)**. LS style coils are considered to be logic level with built in ignitor circuits, which means they can be directly connected to a Microsquirt ignition output, so no external ignition module is needed.

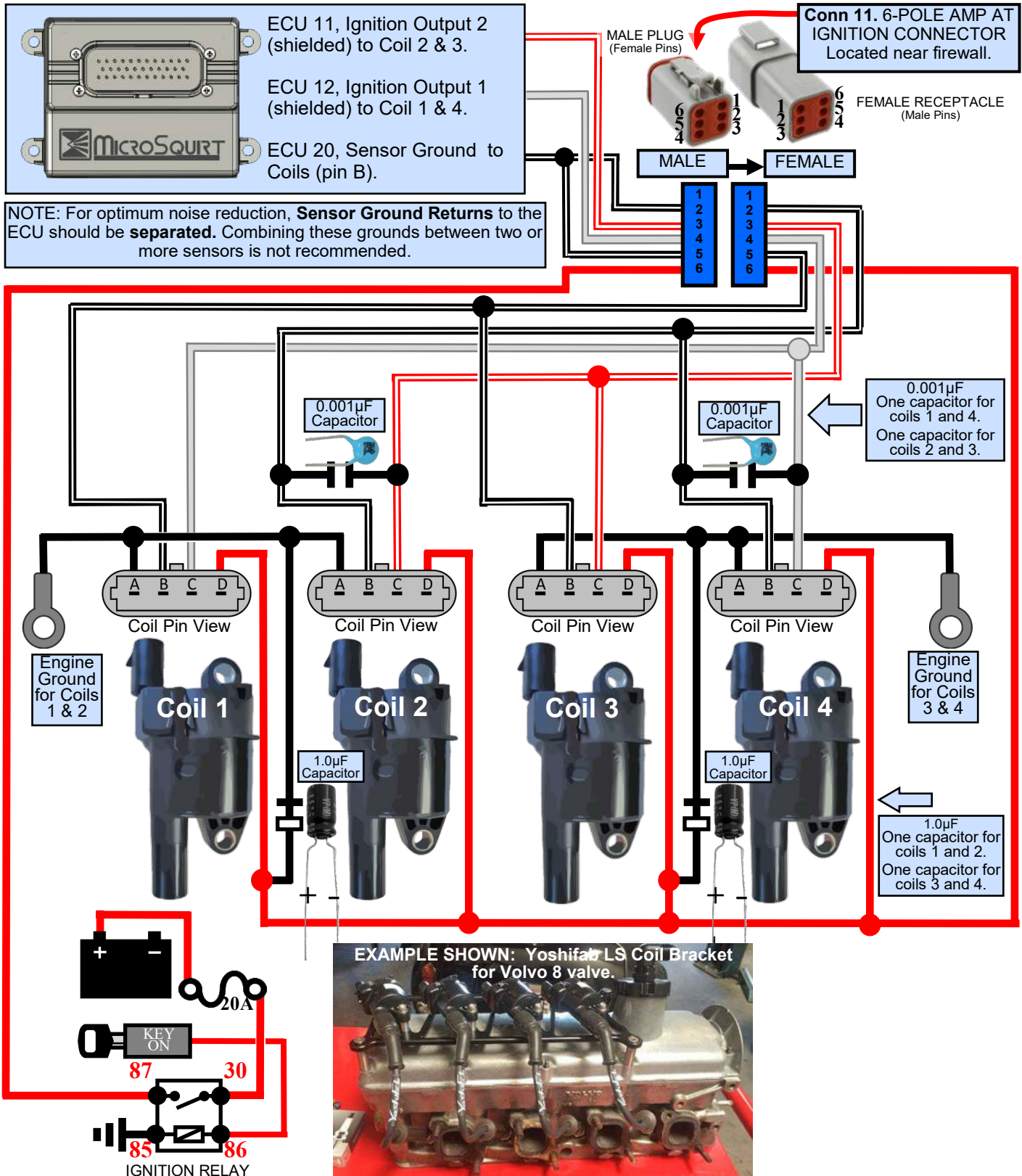

Aptiv (Delphi) Sealed 4-Pole LS Coil Connector Detail



15439568 Aptiv (Delphi) 4-pin LS coil connector housing with seal.



15326267 Delphi 18 gauge female terminal.



15305351 Delphi cable seal 18 gauge.



15305171 Delphi cavity plug seal (not needed).

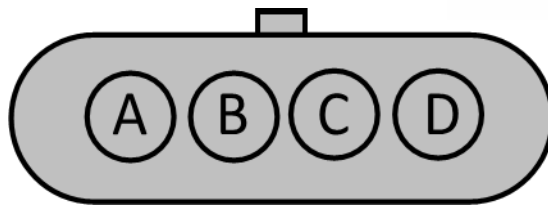

View of Connector REAR

The above connector fits the following LS coils:
D581 (12558693) Truck Coil
D585 (10457730 AC Delco)(19005218 Delphi) Yukon/Truck Coil
D513A (12570616) LS2/LS7 - 1st design
D514A (12573190) LS2/LS7 – 2nd design
MSD (PN# 82478) LS2/LS7 Multiple Spark Coil
GM (12611424) 2005+ LS3 LSA

Optional Coil Harness VE-5729 Coil On Plug (COP) Harness (Denso 129700-3881 Pencil Coils)

VE-5729 COP Harness includes 6-pole Amphenol AT plug, a 14-pole plug for the ignition module, four coil plugs and ground ring.

Coil connectors below are labeled "P1," "P2," "P3," and "P4."

This harness is intended for use with a YOSHIFAB FOUR-CHANNEL IGNITION MODULE, which may be mounted on the firewall.

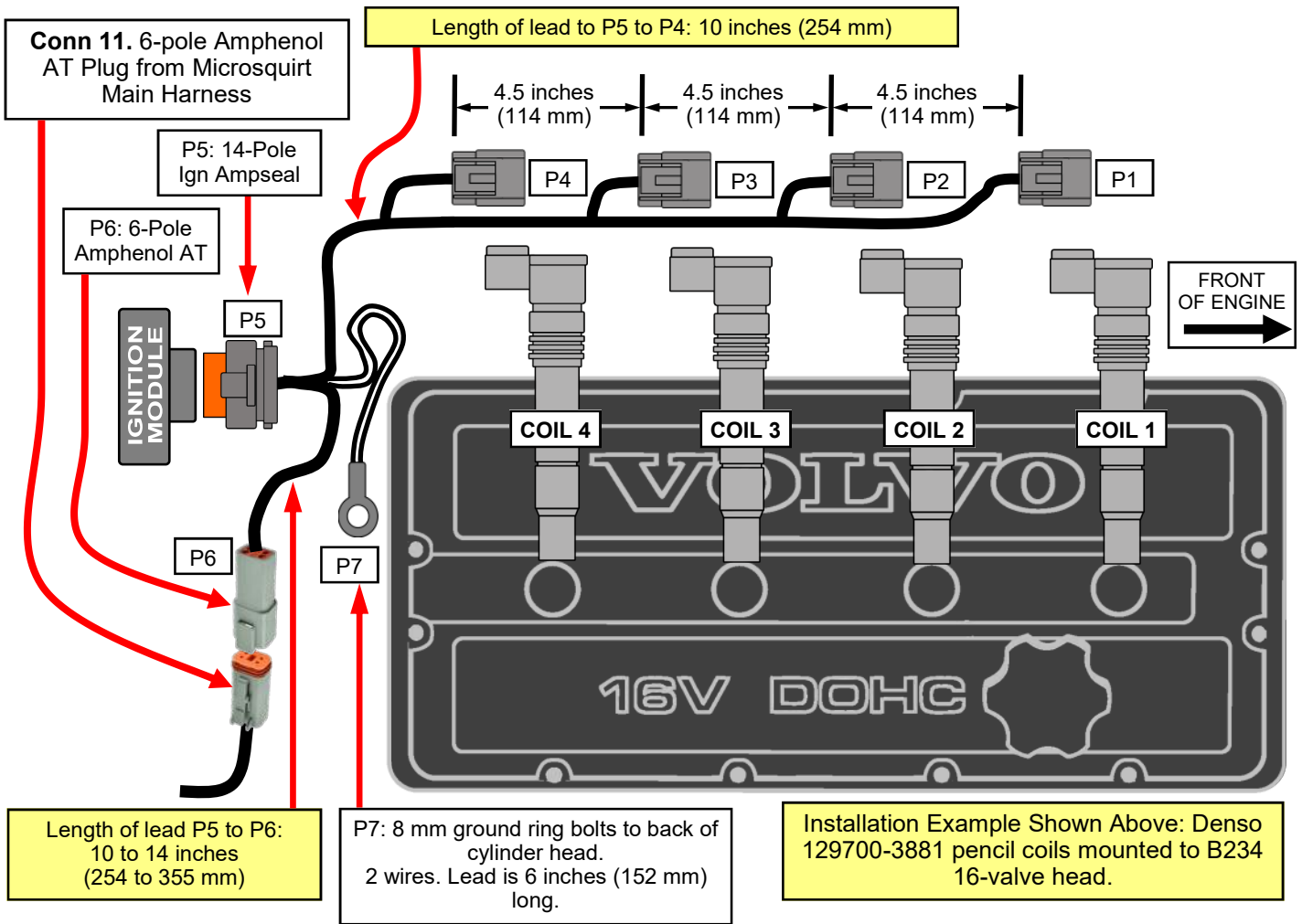

Detail for 2-Pole Coil Connectors for Coils P1, P2, P3 and P4 (No Shields used on Coil Side of P5 14-pole Ignition Module Plug)

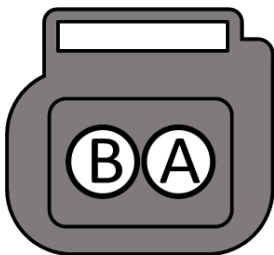

REAR VIEW OF CONNECTOR

- A. Red (all)
- B. (P1) Black
- B. (P2) Black
- B. (P3) Black
- B. (P4) Black

(ALL COIL PLUGS) goes to 12v power through Connector P6, pin 6.
 Goes to 14-pole Ign Ampseal, pin 2.
 Goes to 14-pole Ign Ampseal, pin 11.
 Goes to 14-pole Ign Ampseal, pin 4.
 Goes to 14-pole Ign Ampseal, pin 13.

Optional Coil Harness VE-5729 Coil On Plug (COP) Harness (continued) (Denso 12977 Pencil Coils)

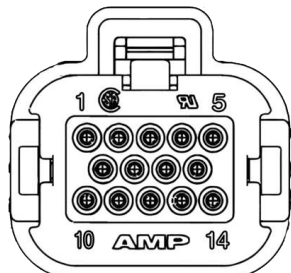

REAR VIEW OF CONNECTOR

Detail for 14-Pole Ampseal Ignition Module Connector P5

- | | |
|---|---|
| <ol style="list-style-type: none"> 1. White 2. Black 3. Black 4. Black 5. White 6. empty 7. empty 8. empty 9. empty 10. Red/Wht 11. Black 12. Black 13. Black 14. Red/Wht | <p>To Firewall Connector P6, pin 4 (common with Ampseal 5).
To Coil Connector P1, pin B.
To Engine Ground Ring P7.
To Coil Connector P3, pin B.
To Firewall Connector P6, pin 4 (common with Ampseal 1).</p> <p>To Firewall Connector P6, pin 3 (common with Ampseal 14).
To Coil Connector P2, pin B.
To Engine Ground Ring P7.
To Coil Connector P4, pin B.
To Firewall Connector P6, pin 3 (common with Ampseal 10).</p> |
|---|---|

FEMALE RECEPTACLE (Male Pins)



REAR VIEW OF CONNECTOR

Detail for 6-Pole Amphenol AT Plug P6

- | | |
|--|---|
| <ol style="list-style-type: none"> 1. Black 2. empty 3. Red/Wht 4. White 5. empty 6. Red | <p>Shield.</p> <p>To 14-pole Ampseal pins 10 and 14.
To 14-pole Ampseal pins 1 and 5.</p> <p>12v power to Coil Connectors P1, P2, P3 and P4, pin A.</p> |
|--|---|

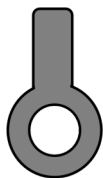

8 mm Ground Ring P7 Bolted to engine ground location at back of cylinder head.

- | | |
|---------------------------------------|---|
| <p>Two wires:
Black
Black</p> | <p>To 14-pole Ampseal pin 3.
To 14-pole Ampseal pin 12.</p> |
|---------------------------------------|---|

End of VE-5729 Coil On Plug (COP) Harness.

Yoshifab Four Channel Ignition Module for Coil On Plug WIRING DIAGRAM

An optional Yoshifab Four Channel Ignition Module is added for use of four pencil style coils for a Coil On Plug (COP) setup for use on a 16 valve head.
Coils depicted are Denso 12977 (i.e.: 12977-3881) or 21171.

These coils are commonly used for motorcycles and are reported to be very reliable.

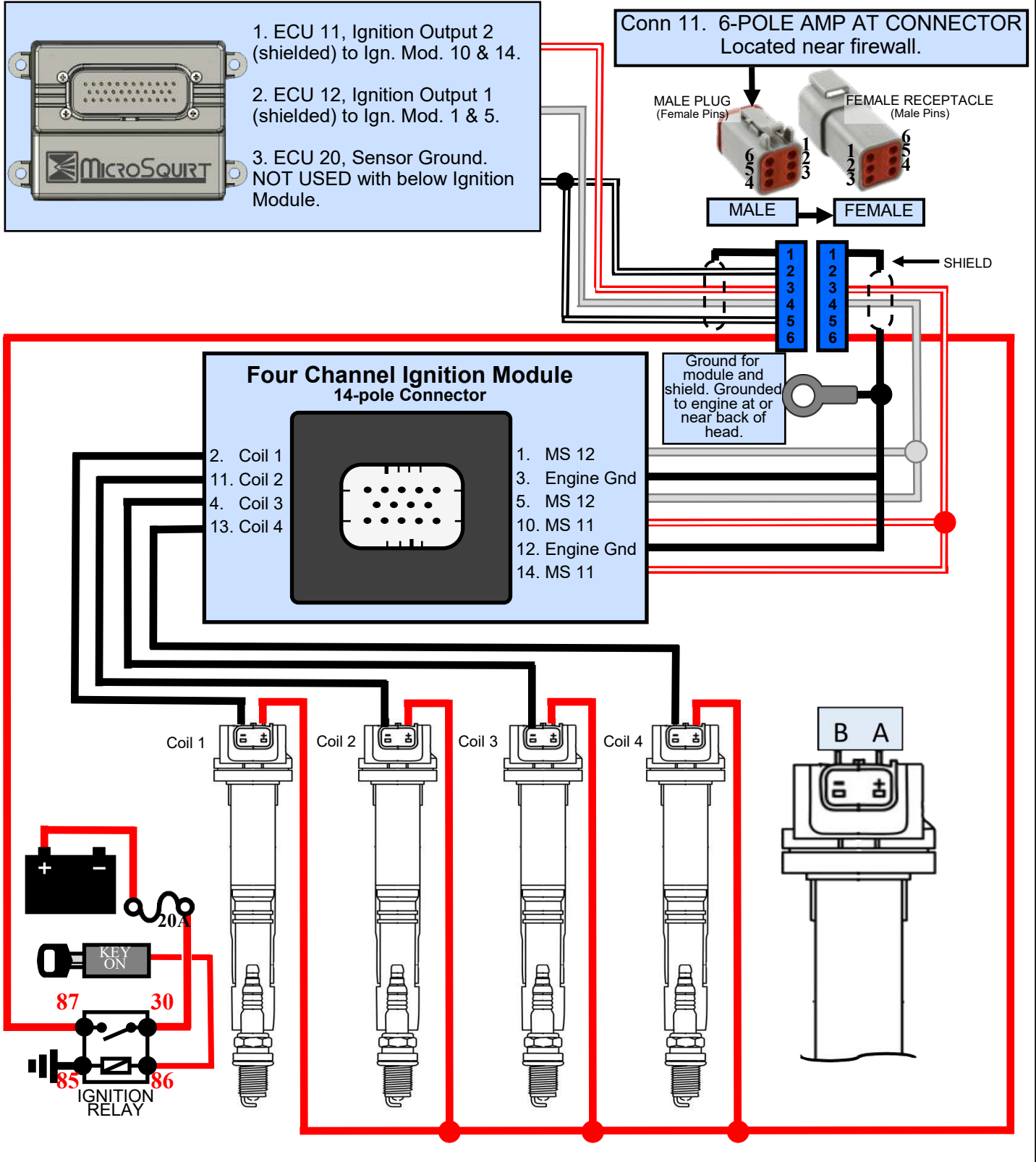

Sealed 2-Pole Pencil Coil Connector Detail

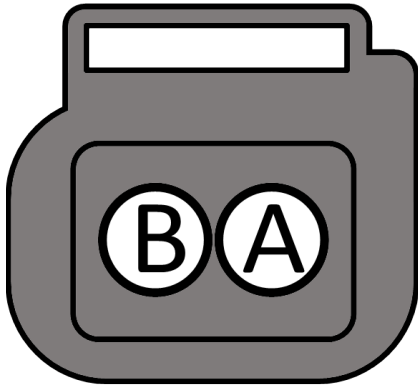

REAR VIEW OF
CONNECTOR



Connector: Furukawa RFW .090 PN: FW-C-2F-B
Source: Eastern Beaver. PN: RFW 2P090-Female
Terminal: RFW-F-125 Female 0.5-1.25mm (16-20 AWG)
Terminal: RFW-F-050 Female 0.3-0.5mm (20-22 AWG)
Wire Seal: RFW-W-D125 Seal 0.5-1.25mm (16-22 AWG)
Wire Seal: RFW-W-B031 Seal 0.85-0.3mm (18-24 AWG)
Wire Seal: RFW-W-B020 Seal 0.5-0.2mm (20-26 AWG)

Yoshifab Four Channel Ignition Module

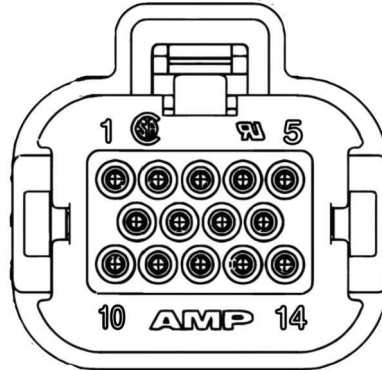

14-pin Ampseal connector
PIN NUMBERS
and PINOUT Information

VIEW FROM BACK OF CONNECTOR.

PIN	NAME	WIRE COLOR	DESTINATION and DESCRIPTION
1.	Module 1	White	To Microsquirt ECU Pin 12 Ignition Output 1 (shielded).
2.	Coil 1	Black	To Coil 1 Pin B NEGATIVE.
3.	Engine Ground	Black	To engine ground.
4.	Coil 3	Black	To Coil 3 Pin B NEGATIVE.
5.	Module 3	White	To Microsquirt ECU Pin 12 Ignition Output 1 (shielded).
6.	Not used		
7.	Not used		
8.	Not used		
9.	Not used		
10.	Module 2	Red/Wht	To Microsquirt ECU Pin 11 Ignition Output 2 (shielded).
11.	Coil 2	Black	To Coil 2 Pin B NEGATIVE.
12.	Engine Ground	Black	To engine ground.
13.	Coil 4	Black	To Coil 4 Pin B NEGATIVE.
14.	Module 4	Red/Wht	To Microsquirt ECU Pin 11 Ignition Output 2 (shielded).

AMPSEAL 14-Pin Connector Detail for Yoshifab Ignition Module 776273-4 (GRAY) (crimp terminals used: 770854-1)

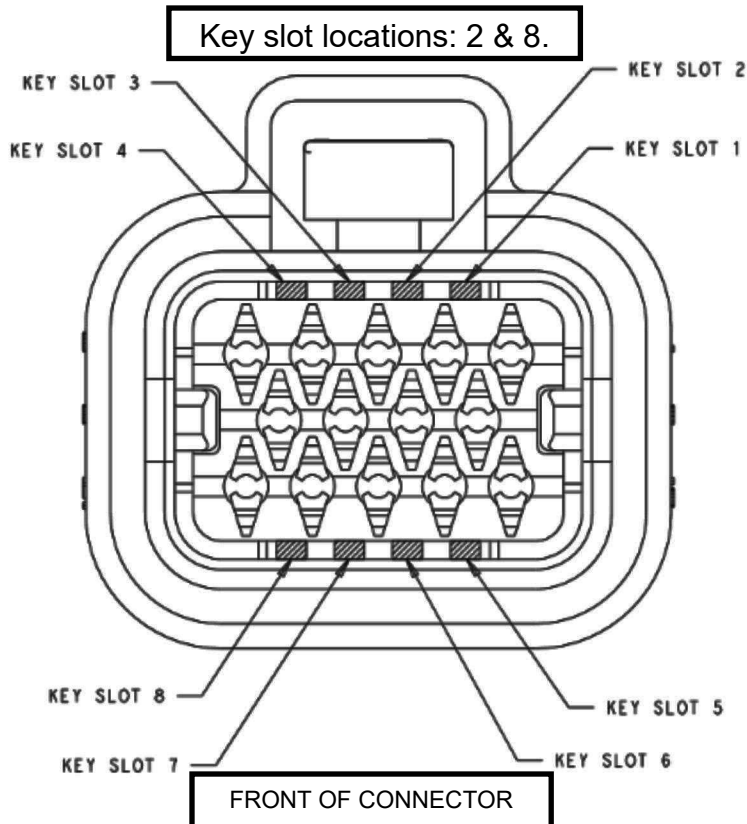
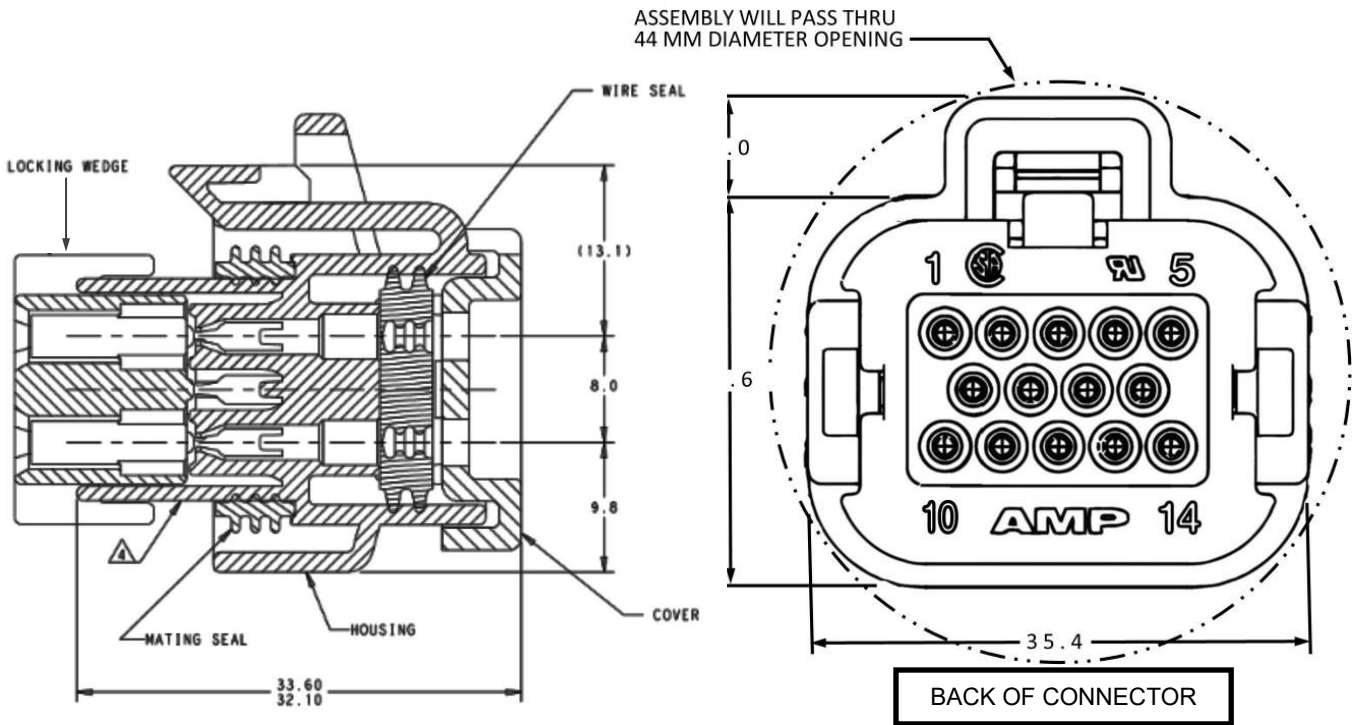

3 & 5	BLUE	776273-5
2 & 8	GREY	776273-4
1 & 6	NATURAL	776273-2
3 & 7	BLACK	776273-1
KEY SLOT LOCATION (SEE VIEW ABOVE)	COLOR	PART NUMBER

14-POSITION CONNECTOR
KEY SLOT LOCATIONS

12

Microsquirt External Ground.
8 mm Ground Ring. 10 inches (254 mm) from Junction 4.
Bolted to preferred engine ground location at back of cylinder head.

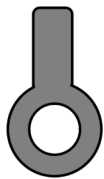

Two wires:

- Black To Conn. 1, pin 3, 35-pole Ampseal.
- Black To Conn. 1, pin 12, 35-pole Ampseal.

13

3-Pole Female EFI (JT) Connector

Included with Main Harness.

Plug for OPTIONAL Crank Position Sensor (CPS) mounted to back of engine.

5 inches (127 mm) from Junction 5.

SHIELDED

Shield should be grounded to the engine near the sensor.

You may optionally use a Volvo crank position sensor to provide engine speed/timing for Microsquirt. Using this CPS requires you to have a flywheel or flexplate originally found in an LH 2.4 equipped Volvo. The standard Volvo sensor is a VR type triggered by a 60-2 flywheel (58 teeth with 2 teeth missing). This option would allow you to use an ignition distributor if needed. This can be a gutted distributor from an LH 2.2 240 or any distributor from an LH 2.4 240. This trigger configuration may also be used for a distributorless multi-coil ignition. This CPS option is already built into this 240 Microsquirt harness and is available for use without any modification to the harness.

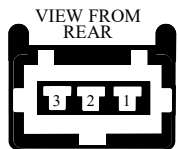

Detail for 13a 3-Pole Female Plug.

- | | | |
|----------------------|--------------------|--------------------------|
| 1. Yellow (shielded) | To Conn. 1, pin 33 | 35-pole Ampseal. VRIN1-. |
| 2. Purple (shielded) | To Conn. 1, pin 32 | 35-pole Ampseal. VRIN1+. |
| 3. Black (shield) | To 13b below | |

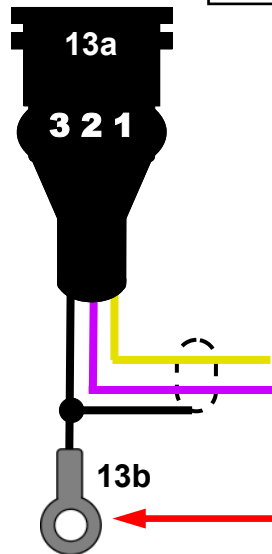

NOTE: This harness uses a resistor connected to the purple and yellow wires. Details are found on the following page.

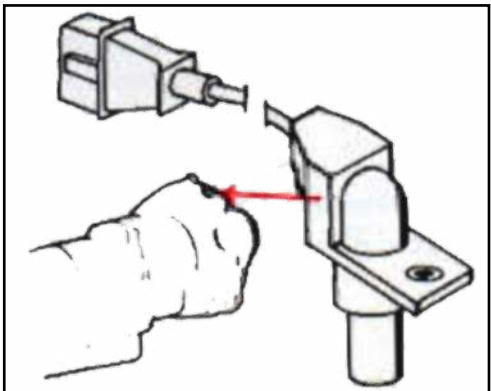

13b Ground Ring (8 mm hole).

Use of this ground ring is not needed if this sensor option is not used.

- WIRE COLOR
Black (shield) To Conn. 4a, pin 3

OPTION: Using your original LH 2.4 Volvo Crank Position Sensor. WIRING DIAGRAM

You may optionally use a Volvo crank position sensor to trigger Microsquirt. This requires you to have a flywheel or flexplate for an LH 2.4 equipped Volvo. The Volvo sensor is a VR type triggered by a 60-2 flywheel (58 teeth with 2 teeth missing). This option would allow you to use an ignition distributor if needed. This can be a gutted distributor from an LH 2.2 240 or any distributor from an LH 2.4 240. This trigger configuration can also be used for a distributorless multi-coil ignition.

This option is built into the 240 Microsquirt harness and is available for use without any modification to the harness.

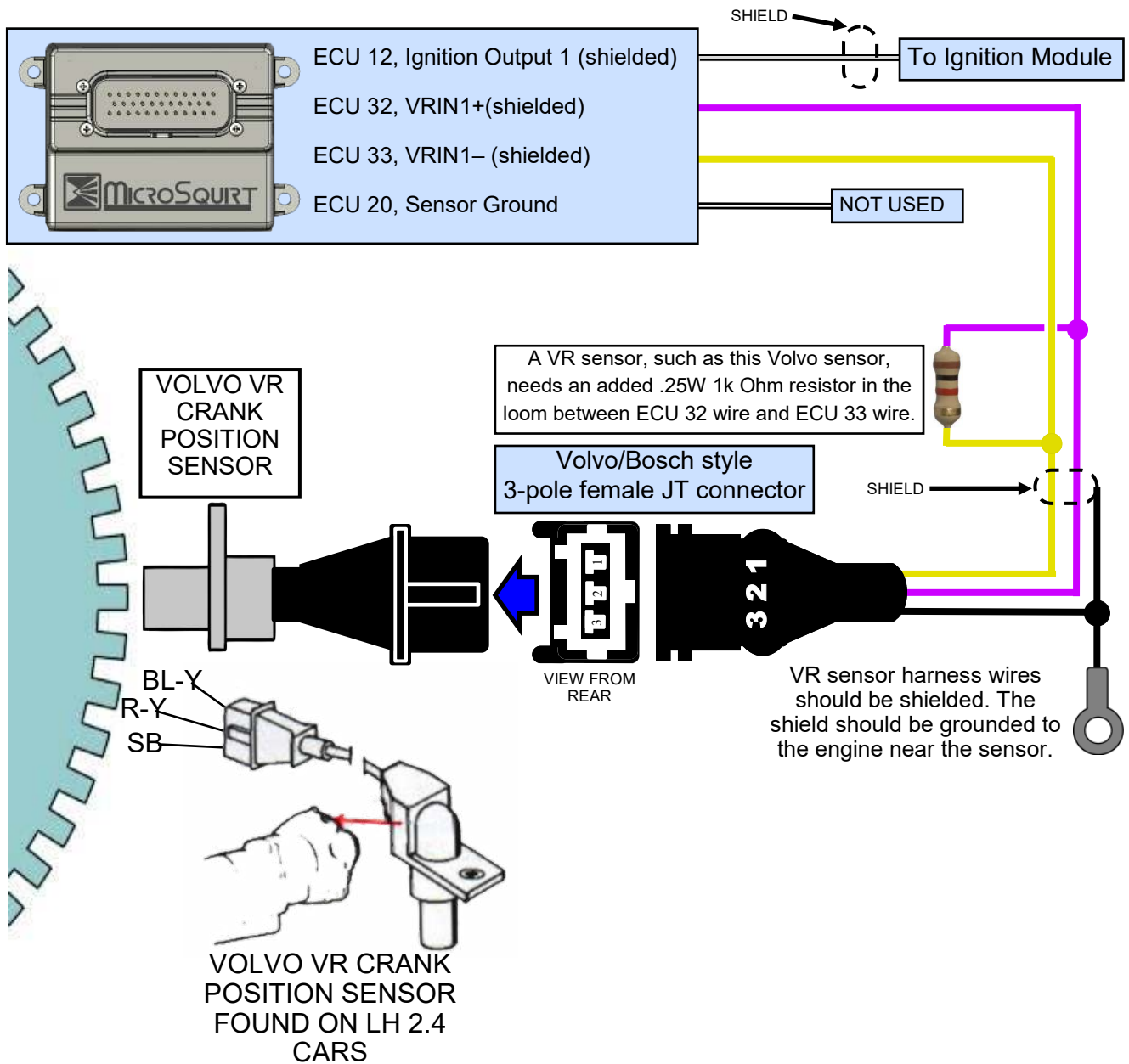

Ignition with Single Coil and MSD. WIRING DIAGRAM

This example uses single coil and an MSD Digital 6A ignition amplifier.

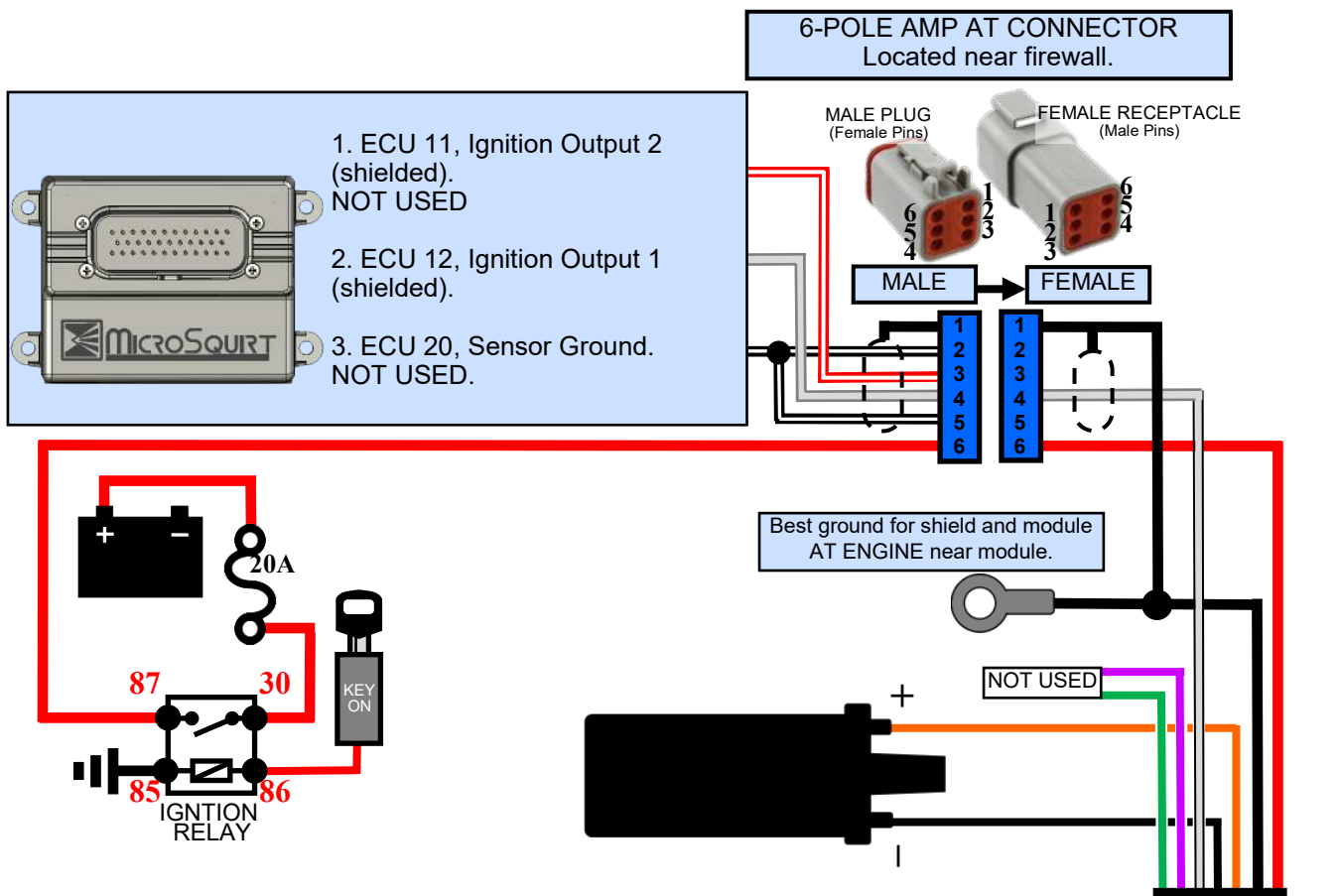

MSD Digital 6A to MicroSquirt General Wiring

The Digital 6A and 6AL use a wiring harness that uses a sealed connection at the module.

Heavy Red	This wire connects directly to the battery positive (+) terminal or a positive battery junction. Do not connect directly to an alternator.
Heavy Black	This wire connects to a good ground, preferably to the battery negative (-) terminal. It can also connect to the engine ground.
Red	Connects to a switched 12 volt source such as the ignition key or switch. Power should be on when the key is in the ON/RUN position and during cranking. (Max current draw of .250 mA.)
Orange	This wire connects to the coil positive (+) terminal. This is the ONLY wire that makes electrical contact with the positive coil terminal.
Black	This wire connects to the coil negative (-) terminal. This is the ONLY wire that makes electrical contact with the negative coil terminal.
White	Connects to MicroSquirt 3 ECU 12 Ignition Output. Normally used for an input from breaker points, an ignition amplifier output or to the Yellow wire of an MSD Timing Accessory. When this wire is used, the below magnetic pickup wires are not used.
Violet and Green (Magnetic Pickup Connector)	Not used for MicroSquirt 3. These wires are normally used together for a magnetic pickup sensor. The Violet wire is positive (+) and the Green wire is negative (-). When these wires are used, the above White wire is not used.
Gray	Not used for MicroSquirt 3. Tach output wire. Connects to the tachometer trigger wire or other rpm activated device.
Red Loop Blue Loop	These are the cylinder-select wire loops. MSD is wired for an 8 cylinder engine by default. One of the loops gets cut for a 6-cylinder engine. Both loops get cut for a 4-cylinder engine.



MICROSQUIRT Engine Harness for 240

14

8-Pole Female Volvo Bullet Firewall Connector.
LEFT side firewall.
7 inches (178 mm) lead from Junction 5.

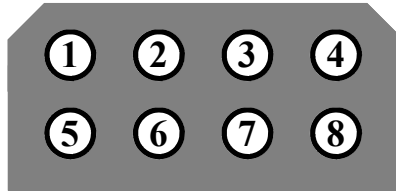

VIEW FROM REAR

1. Black	To Conn. 29	Oil pressure sender.
2. Yellow	To Conn. 24	1-pole coolant temp sender (for dash cluster gauge).
3. Red	To Conn. 27	Alternator D+ wire.
4. empty		
5. Blu/Yel	To Conn. 19	Starter solenoid.
6. Green	To Conn. 28	Oil pressure sender (for 52 mm gauge).
7. empty		
8. empty		

15

Detail for 3-Pole MAP Sensor Connector.
For GM MAP Sensor. 30 inches (760 mm) lead from Junction 5.
Wires should be TWISTED TRIAD configuration.

MAP Sensor AC Delco 12223861

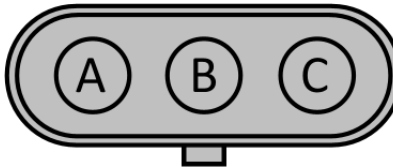

PLUG REAR VIEW



Delphi (Aptiv)
12015796

A. Blk/Wht	To Conn. 1, pin 20	35-pole Ampseal. Sensor Ground Return.
B. Red/Grn	To Conn 1, pin 24	35-pole Ampseal. MAP Output.
C. Gray	To Conn. 1, pin 28	35-pole Ampseal. Vref.

16

Detail for 2-Pole Coolant Temp (CLT) Sensor Connector.
10 inches (254 mm) lead from Junction 6.
Wires should be TWISTED PAIR configuration.

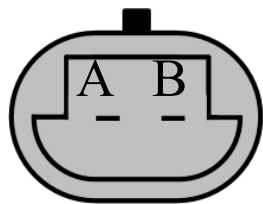

PLUG REAR VIEW

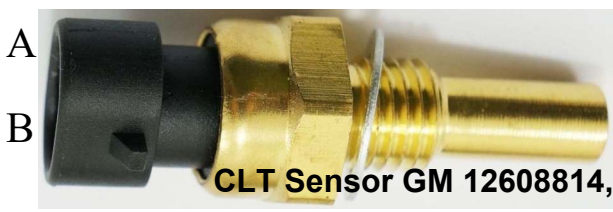

CLT Sensor GM 12608814, M12x1.5

A. Yellow	To Conn. 1, pin 25	35-pole Ampseal. CLT.
B. Blk/Wht	To Conn 1, pin 20	35-pole Ampseal. Sensor Ground Return.

The above GM sensor is suggested in Microsquirt literature, however other sensors are possible. The threads in a Volvo head will be M12x1.5, so a sensor matching that thread is needed. The Bosch NTC M12 has also been suggested. It was used in a BMW E30. Also a sensor from an LH 2.2 Volvo (PN 0280130026) can be used. Both have M12x1.5 thread and the calibration curves are not hard to find. A standard Bosch 2-pole EFI pug would need to be used for these.

17

Detail for 3-Pole Female Connector. Throttle Position Sensor (TPS).
18 inches (457 mm) lead from Junction 6.
Wires should be TWISTED TRIAD configuration.



1. Blk/Wht	To Conn. 1, pin 20.	35-pole Ampseal. Sensor Ground Return
2. Gray	To Conn. 1, pin 28.	35-pole Ampseal. +5 Vref.
3. Blue	To Conn. 1, pin 27	35-pole Ampseal. TPS Sense.

TPS TERMINAL IDENTIFICATION GUIDE:

Volvo PN 1336385 TPS is the most common one used for MS. This is the **potentiometer style** TPS used for the 240 (LH 3.1), 850 and 960 engines.

Other potentiometer style sensors can be used. To identify or confirm which terminals to use for the above connections **on a different TPS**, use a multi-meter set to measure resistance (Ohms). Find the two pins where the resistance does not change when the throttle is moved. One of these two pins will be +5 Vref, which is the voltage input from the ECU. The other will be the GROUND. The remaining third pin will be the TPS sense pin (usually the center pin). The TPS sense pin supplies the varied output voltage signal back to the ECU depending on throttle position.

Now you need to determine which of the **FIRST TWO** pins is 5+ Vref and which is the GROUND. These two might be reversed depending on the make of the sensor. Using an Ohm setting on your meter, connect one lead to the TPS sense pin, which you have already identified. With the TPS in the idle position, connect the other lead to one of the other two pins. The pin with the lowest resistance to the TPS sense pin will be the GROUND. The pin with higher resistance to the TPS sense pin will be the +5 Vref. You can confirm this pin by rotating the throttle. The resistance should becomes LOWER as you OPEN the throttle. This function is used to increase output voltage from the TPS from about 0.5 - 1 volt at idle to about 5 volts at full throttle.



18

Starter B+ Battery Cable.

Cable size: 16 mm2. Standard 8 mm ring for starter.

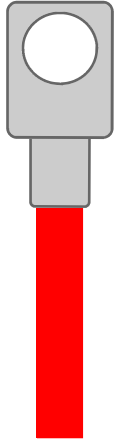

Red (fat cable) To Conn. 26 Alternator B+

THIS CABLE IS SEPARATE, OUTSIDE OF THE MAIN HARNESS, SO THAT THE ALTERNATOR MAY OPTIONALLY BE MOUNTED ON THE RIGHT OR LEFT SIDE.

2. NOT USED

VIEW OF FRONT OF STARTER

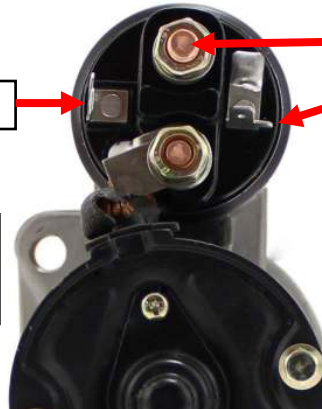

1. LARGE CABLE STUD

3. SOLENOID

LEFT FENDER →

19

Starter Solenoid Wire.

6.3 mm female terminal with insulator.
About 8 inches (203 mm) from Junction 6.



Blu/Yel To Conn. 14, pin 5 8-pole Volvo Firewall Connector

2. NOT USED

VIEW OF FRONT OF STARTER

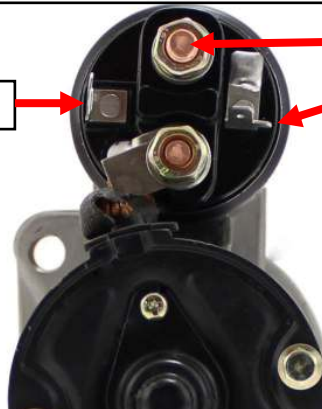

1. LARGE CABLE STUD

3. SOLENOID WIRE

LEFT FENDER →

20

Detail for 2-Pole Intake Air Temp (IAT) Sensor Connector.
20 inches (508 mm) lead length from Junction 6.

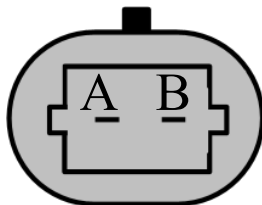

PLUG REAR VIEW



IAT Sensor GM 25037334, 25036751 (3/8x18 NPTF)

A. Orange	To Conn. 1, pin 26	35-pole Ampseal. IAT.
B. Blk/Wht	To Conn 1, pin 20	35-pole Ampseal. Sensor Ground Return.

Engine Sensor Connector Detail

CLT Sensor GM 12608814

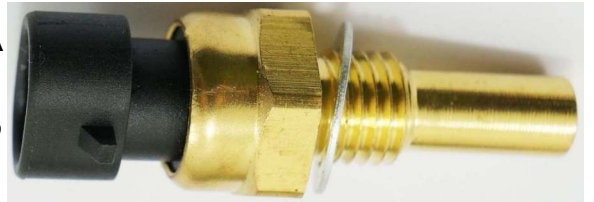
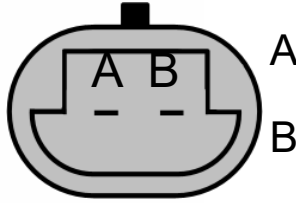

GM Coolant Temp Sensor Plug

GM #12101899, 12046623.
Delphi 12162193, 150.2 Metri-Pack.
Conductite/Dorman 85100.

Terminal

Delphi 12103881, 150 Series Pull-To-Seat
Metri-Pack Terminal.

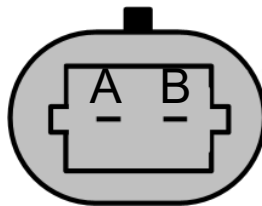

IAT Sensor GM 25037334, 25036751



GM IAT Sensor Plug

GM #12101899, 12046623.
Delphi 12162199, 12162197, 150.2 Metri-Pack.
Conductite/Dorman PN 85110.

Terminal

Delphi 12103881, 150 Series Pull-To-Seat
Metri-Pack Terminal.

Engine Sensor Connector Detail



MAP Sensor AC Delco 12223861

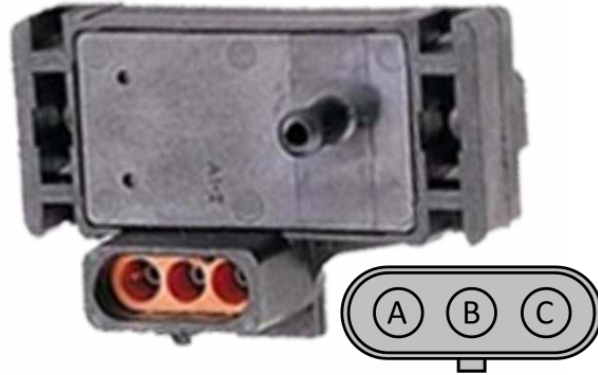

GM MAP Sensor Tower Plug

Delphi (Aptiv) 12015796 (Black color)

Delphi (Aptiv) 12041332-B (Orange color)

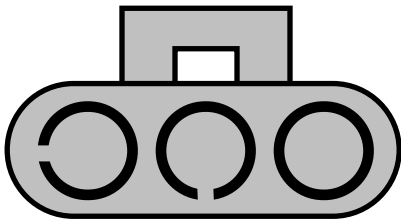

CONNECTOR INDEXING
SLOT DETAIL.
VIEW OF FRONT.

Terminal

Delphi 12089040-L (18-20 AWG) MALE

Delphi 12124582-L (14-16 AWG) MALE



FUEL INJECTORS

WIRING DIAGRAM

MicroSquirt 3 has two injector driver outputs. Each driver is assigned two fuel injectors for a four-cylinder harness. High-impedance (saturated type) injectors are supported without any changes. If you will be using low-impedance (peak and hold type) injectors, they will require resistors wired in series. This information is detailed below.

The four pole connector below is intended to remain in the dash area and is included in case you wish to optionally install an injector resistor pack (which will also reside in the dash area) without having to cut the harness.

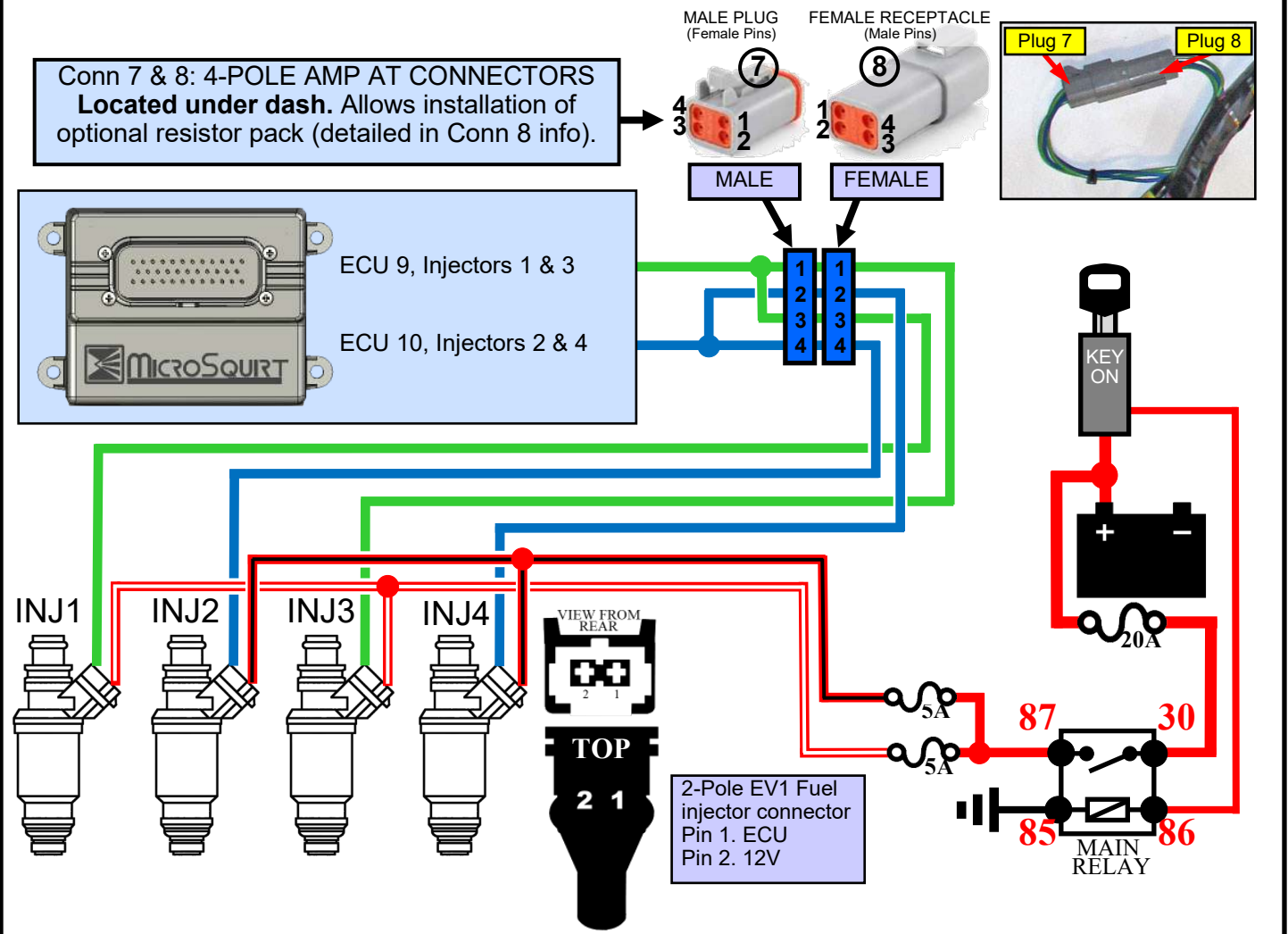

21

Detail for 2-Pole EV-1 Style Fuel Injector Connectors.
(FOUR Connectors).

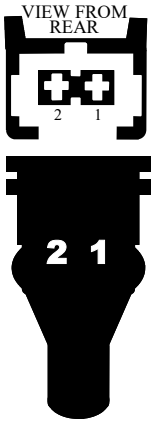

21a (Injector 1)	13 inches (330 mm) from Junction 7.
1. Green	To Conn. 8, pin 1 4-pole MALE Amphenol AT plug.
2. Red/White	To Conn. 4b 5 amp fuse. Then to Conn. 4, pin 87.
21b (Injector 2)	11 inches (279 mm) from Junction 7.
1. Blue	To Conn. 8, pin 2 4-pole MALE Amphenol AT plug.
2. Red/Black	To Conn. 4c 5 amp fuse. Then to Conn. 4, pin 87.
21c (Injector 3)	11 inches (279 mm) from Junction 7.
1. Green	To Conn. 8, pin 3 4-pole MALE Amphenol AT plug.
2. Red/White	To Conn. 4b 5 amp fuse. Then to Conn. 4, pin 87.
21d (Injector 4)	13 inches (330 mm) from Junction 7.
1. Blue	To Conn. 8, pin 4 4-pole MALE Amphenol AT plug.
2. Red/Black	To Conn. 4c 5 amp fuse. Then to Conn. 4, pin 87.

22

6 mm Ground Ring

Ring grounded to engine. Typically at fuel rail attachment bolt to intake manifold.
9 inches (228 mm) from Junction 7.



Black.	To Shield at Conn. 25.	Ground for shield.
--------	------------------------	--------------------

23

Detail for 2-pole EV-1 Style Connector for 2-pole Idle Air Control (PWM IAC) Valve.
By default, this harness is configured for a Bosch style 2-pole IAC valve using a diode as shown below.

A Bosch 2-pole IAC valve, PN 0 280 140 516, was used in LH 2.4 Volvos.

LENGTH: 12 inches (305 mm) from Junction 8.

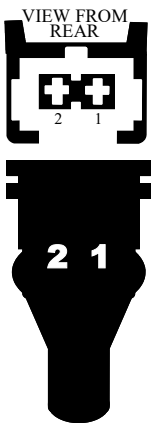

1. Green	To Conn. 1, pin 7	35-pole Ampseal. F-idle/IAC.
2. Red	To Conn. 4, pin 87	Power from Main Relay.

This connector uses a diode as shown.

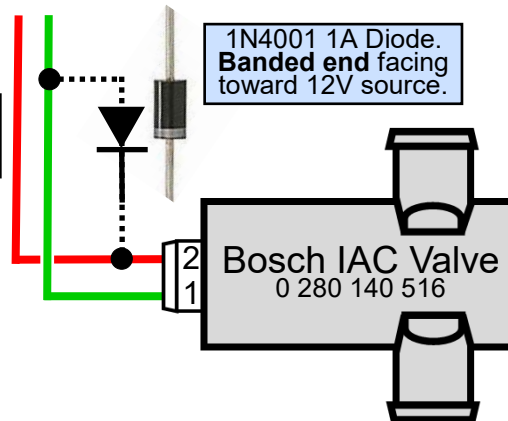

24

1-Pole Coolant Temp Sender (for dash cluster gauge).

6.3 mm female terminal with insulator.
8 inches (203 mm) from Junction 8.

NOTE: A 2-pole Volvo 740 (1987 and later, PN 1362645) style temp sender is not supported by this harness.
This harness is intended to use a 1-pole VDO sender used by a 240, Volvo PN 460191.
Sender threads: 5/8-18 UNF.

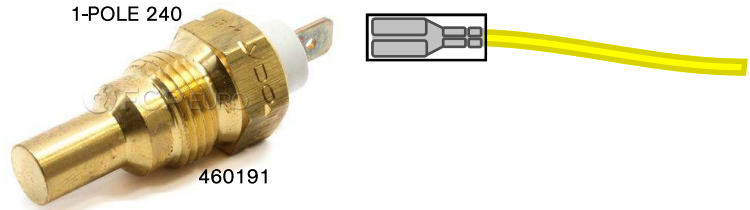
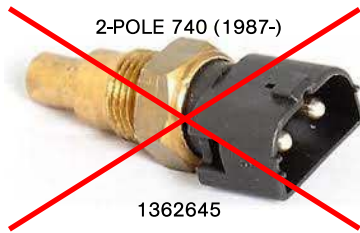

Yellow To Conn. 14, pin 2 8-pole Female Volvo Firewall Connector.

CAS/DISTRIBUTOR OPTION PLUG

25

Detail for 6-pole Amphenol AT Plug on Main Harness

This plug is found on the Main Harness. It will connect to a short adapter harness of your choice for either a
1. VE-5727 Harness for Yoshifab DSM 24+1 Optical Cam Angle Sensor (CAS) or
2. VE-5725 Harness for use of an LH 2.2 Hall Distributor.

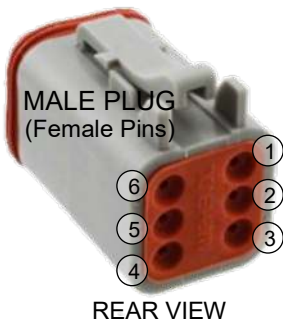

1. Blk/Wht	To Conn. 1, pin 20	35-pole Ampseal. Sensor Ground Return.
2. Red (fat)	To Conn. 6, pin 87	Ignition Relay Plug.
3. Yellow	To Conn. 1, pin 33	35-pole Ampseal. VRIN1-.
4. Black	To Conn. 1, pin 21	35-pole Ampseal. VRIN2-.
5. Gray	To Conn. 1, pin 28	35-pole Ampseal. Vref.
6. - empty		
SHIELD: Black	To Conn. 22	Ground Ring for engine shield ground.

CAS OPTION

Yoshifab DSM 24+1 Optical Cam Angle Sensor (CAS) Ver.2

This CAS replaces the block mounted distributor in a 240 engine and provides triggering for Microsquirt ignition inputs. No distributor is used with this configuration.



WIRE COLORS FOR CAS (4-POLE CONNECTOR):

- 1. Black Microsquirt ECU Pin 20 sensor ground.
- 2. Red 12V switched.
- 3. Yellow Microsquirt ECU Pin 33 VRIN1- for crank signal (shielded).
- 4. White Microsquirt ECU Pin 21 VRIN2- for cam signal (shielded).

NOTE: For optimum noise reduction, all **Sensor Ground Returns** should be separate. Do not combine these grounds between two or more sensors.

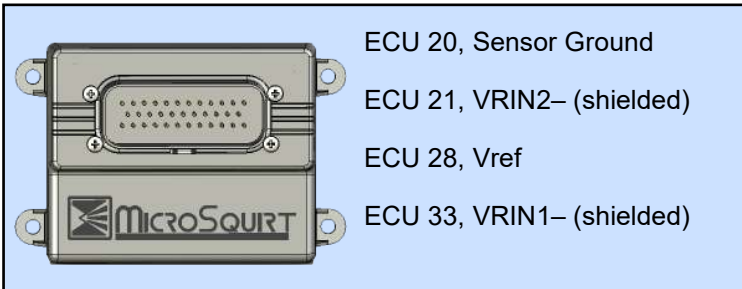

Ground for shield at engine near CAS

6-POLE AMP AT CONNECTOR to Resistor Harness.



- Wire colors at Yoshifab 240 CAS
- 1. Black
 - 2. Red
 - 3. Yellow
 - 4. White

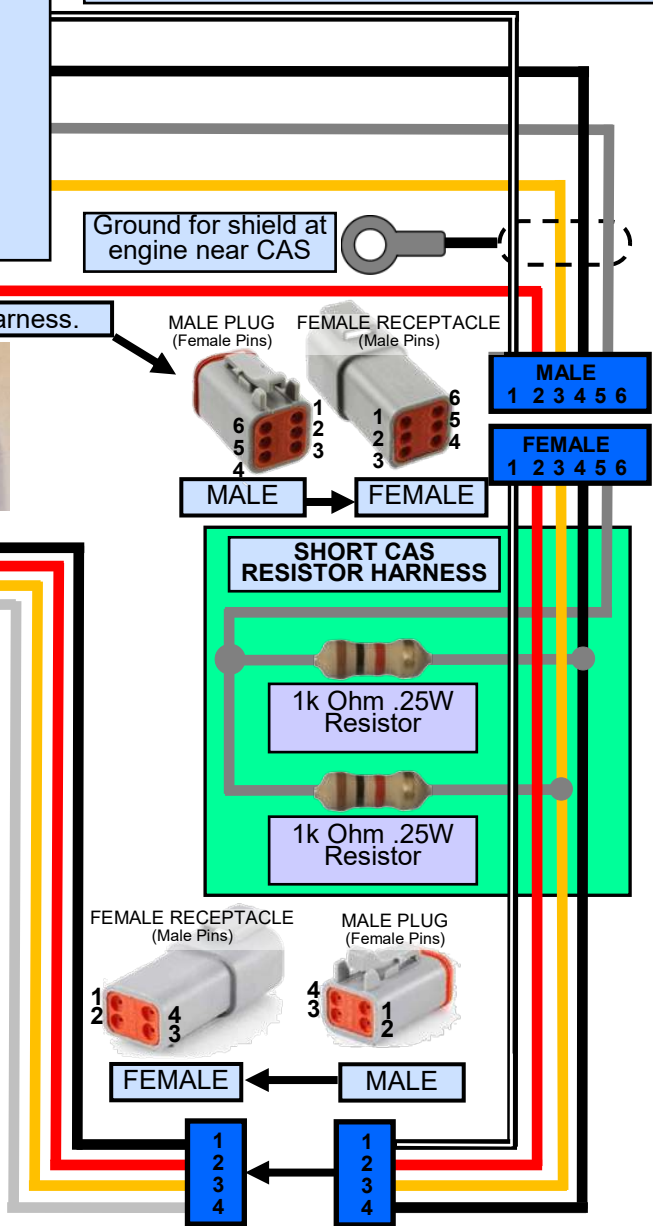
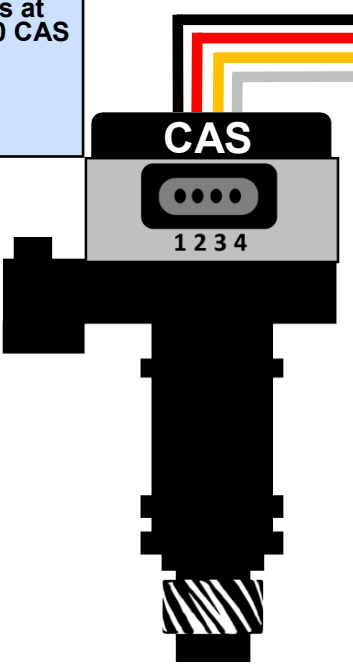
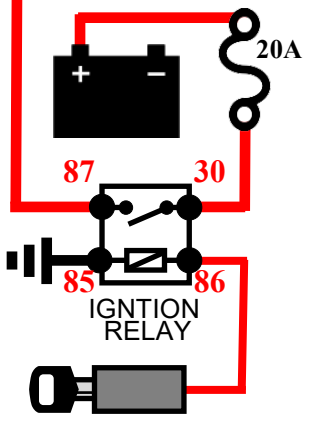

HALL DISTRIBUTOR

VE-5725 Optional Resistor Adapter Harness

This short harness connects between Connector 25 and a block-mounted Volvo LH 2.2 style Distributor.

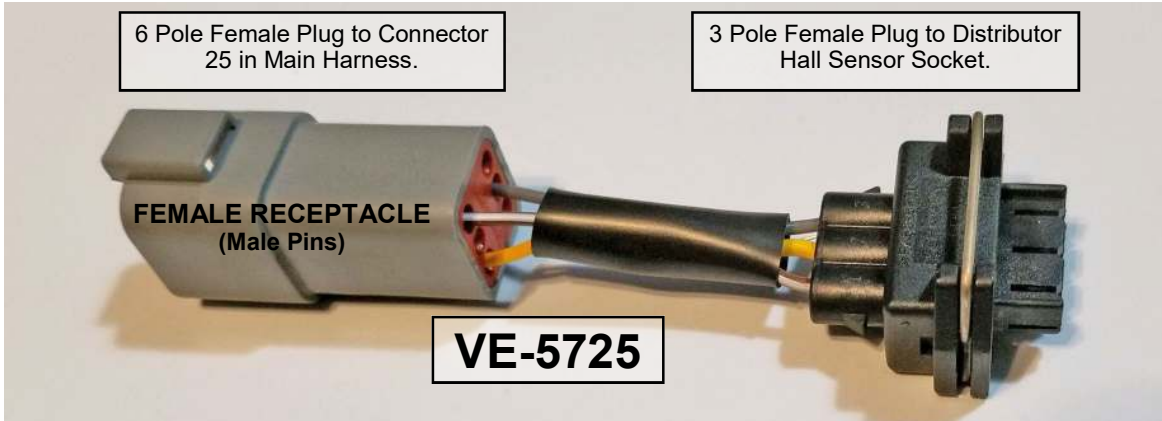

6 Pole Female Plug to Connector 25 in Main Harness.

3 Pole Female Plug to Distributor Hall Sensor Socket.

FEMALE RECEPTACLE
(Male Pins)

VE-5725

6-pole Amphenol AT FEMALE RECEPTACLE connects to **Connector 25 in Main Harness.**



6-pole
Amphenol AT
MALE

MALE
1 2 3 4 5 6

- 1. Blk/Wht
- 2. - empty
- 3. Yellow
- 4. - empty
- 5. White
- 6. - empty

This harness uses a resistor connected to the white and yellow wires.

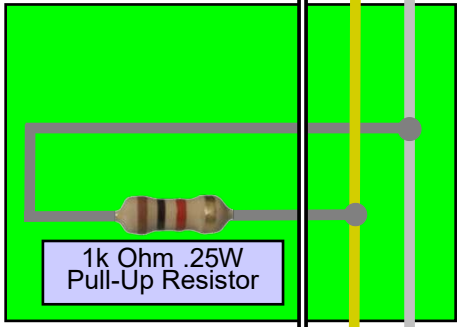

1k Ohm .25W
Pull-Up Resistor

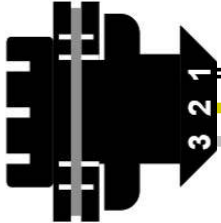
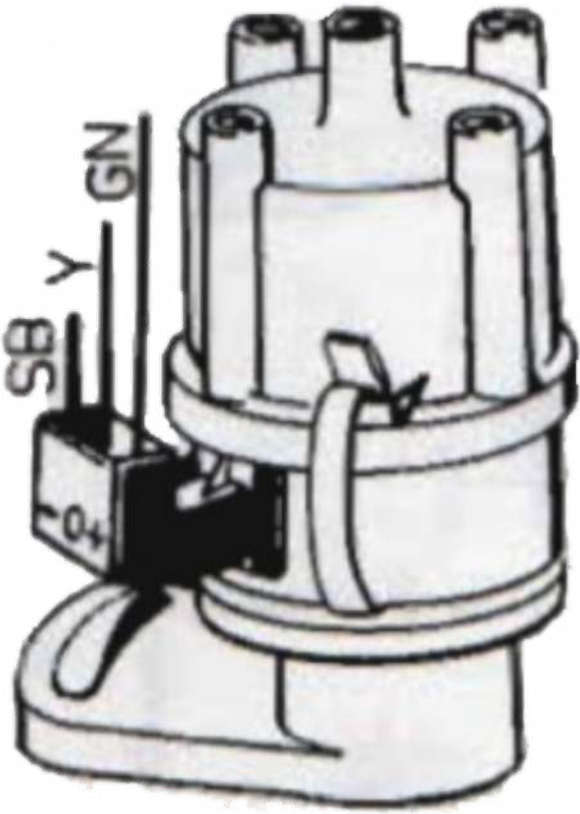

3-pole
Volvo Distributor
Plug



Optional Bosch Ignition Module Harness

VE-5715 Optional Bosch Ignition Module Harness for Single Coil Ignition

This sub-harness may be used when a Volvo LH 2.2 style distributor is to be used to supply the engine speed signal to Microsquirt. Also this sub-harness may be used when an LH 2.4 style CPS is used for the engine speed signal. This sub-harness connects the main MS engine harness (Conn. 11, 6-pole Amphenol AT plug) to the below Bosch single stage ignition module (PN 0 227 100 124) sourced from any LH 2.4 Volvo 240 or and LH 2.2 or 2.4 740.

FEMALE RECEPTACLE
(Male Pins)

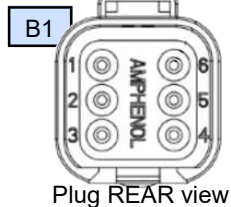

6-Pole Amphenol AT plug **B1** connects to **Conn. 11** on main harness.

- | | |
|---------------------|---|
| 1. Black (shield) | To Conn. B2, pin 2, 7-pole lug. And to B3 Chassis Ground. |
| 2. empty | |
| 3. empty | |
| 4. White (shielded) | To Conn. B2, pin 5, 7-pole plug. |
| 5. empty | |
| 6. Red | To Conn. B2, pin 4, 7-pole plug. |

FEMALE
1 2 3 4 5 6

B3: 6 mm Ring. Ground
lead length from 7-pole
plug: 6 inches (152 mm)

B2: Volvo/Bosch style
7-pole EFI plug.

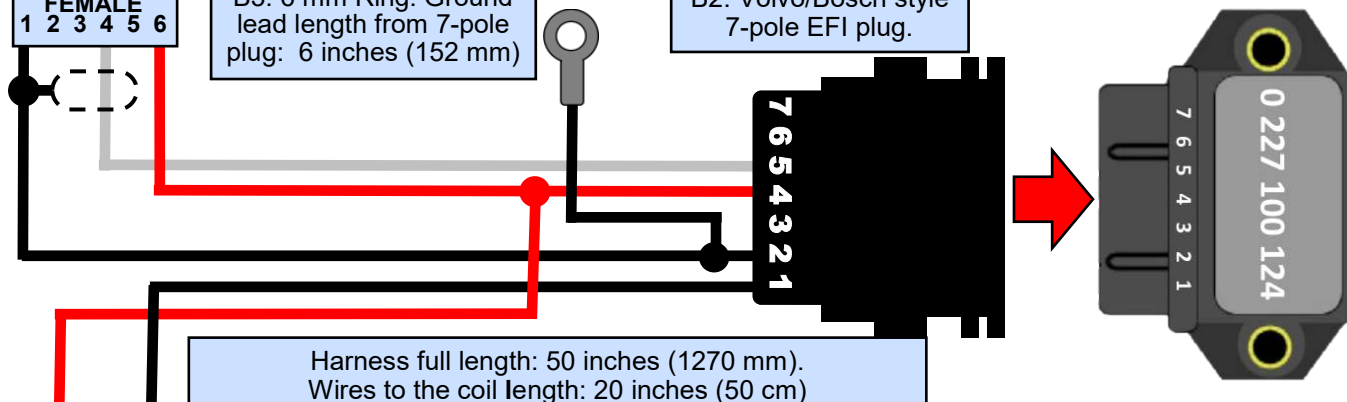

Harness full length: 50 inches (1270 mm).
Wires to the coil length: 20 inches (50 cm)

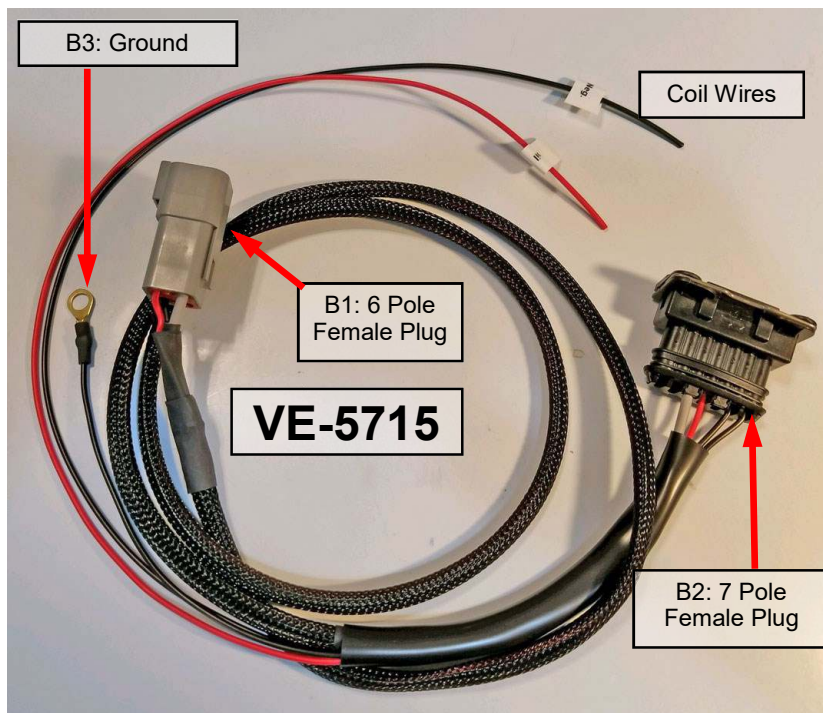

26

Alternator B+ Battery Cable.
Cable size: 16 mm². Standard 6 mm ring for alternator.
CABLE IS SEPARATE FROM MAIN HARNESS

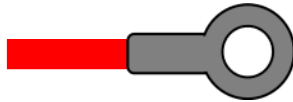

Red (fat cable) Conn. 18 to Starter B+

CABLE IS PROVIDED SEPARATELY, OUTSIDE OF THE MAIN HARNESS, SO THAT THE ALTERNATOR MAY OPTIONALLY BE MOUNTED ON THE RIGHT OR LEFT SIDE.

27

Alternator D+ Alternator Charge Wire #2.
1.0 mm² size wire. 6.3 mm female terminal with insulator.
27b is about 6 inches (150 mm) from Junction 9.

TWO #27 connectors are provided on this harness (27a and 27b). Connector 27a is in the normal place for an alternator mounted on the RIGHT side of the engine. The EXTRA #27b connector is located on the LEFT (intake side) for the option of mounting the alternator on the LEFT side of the engine.



Red To Conn. 14, pin 3 8-pole Female Volvo Firewall Connector.

28

Detail for Oil Pressure Sender (OPS) Green Wire
1.0 mm² size wire. 4.8 mm female terminal with insulator.
35 inches (889 mm) lead from Junction 9.



Green To Conn. 14, pin 6 8-pole Female Volvo Firewall Connector.

This wire is only for an optional 2-pole Oil Pressure Sender for use with a 52 mm OP gauge. If you're using any simple 1-pole Oil Pressure Sender, this wire will not be used.

29

Detail for Oil Pressure Sender (OPS) Black Wire
1.0 mm² size wire. 6.3 mm female terminal with insulator.
35 inches (889 mm) lead from Junction 9.

Black To Conn. 14, pin 1 8-pole Female Volvo Firewall Connector.

If you're using an early style 240 1-pole Oil Pressure Sender with a spade type connection, or if you're using a 2-pole Oil Pressure Sender for use with a 52 mm OP gauge, use this 6.3 mm Female plug shown at left without the adapter.

If you're using a later style 1-pole Oil Pressure Sender with a BULLET type connection, use the below included adapter.

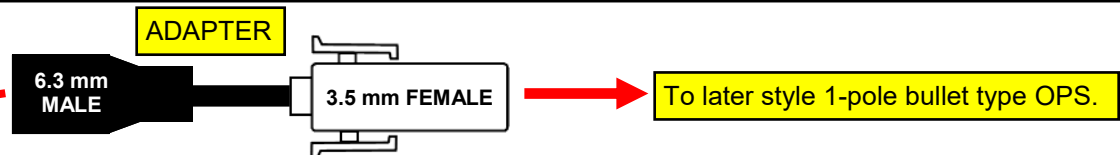
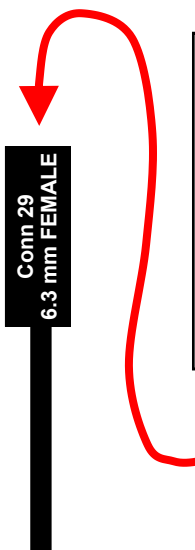

Alternate Stepper Idle Control Valve WIRING DIAGRAM

A stepper motor idle valve is not supported by MicroSquirt 3 out of the box, however, If a stepper motor IAC is required (such as a GM 4-pole IAC), a MicroSquirt Stepper Adapter Module is available as an add on. A guide for this module is available at:

<https://www.efisource.com/docs/Microsquirt-stepper-adapter.pdf>

NOTE: You may choose between using Spare ADC Input 2 or Warm Up LED for this configuration. Be aware that if you are using Spare ADC Input 2 for a MAF sensor, you should use the alternate circuit, Warm Up LED, instead for this setup.

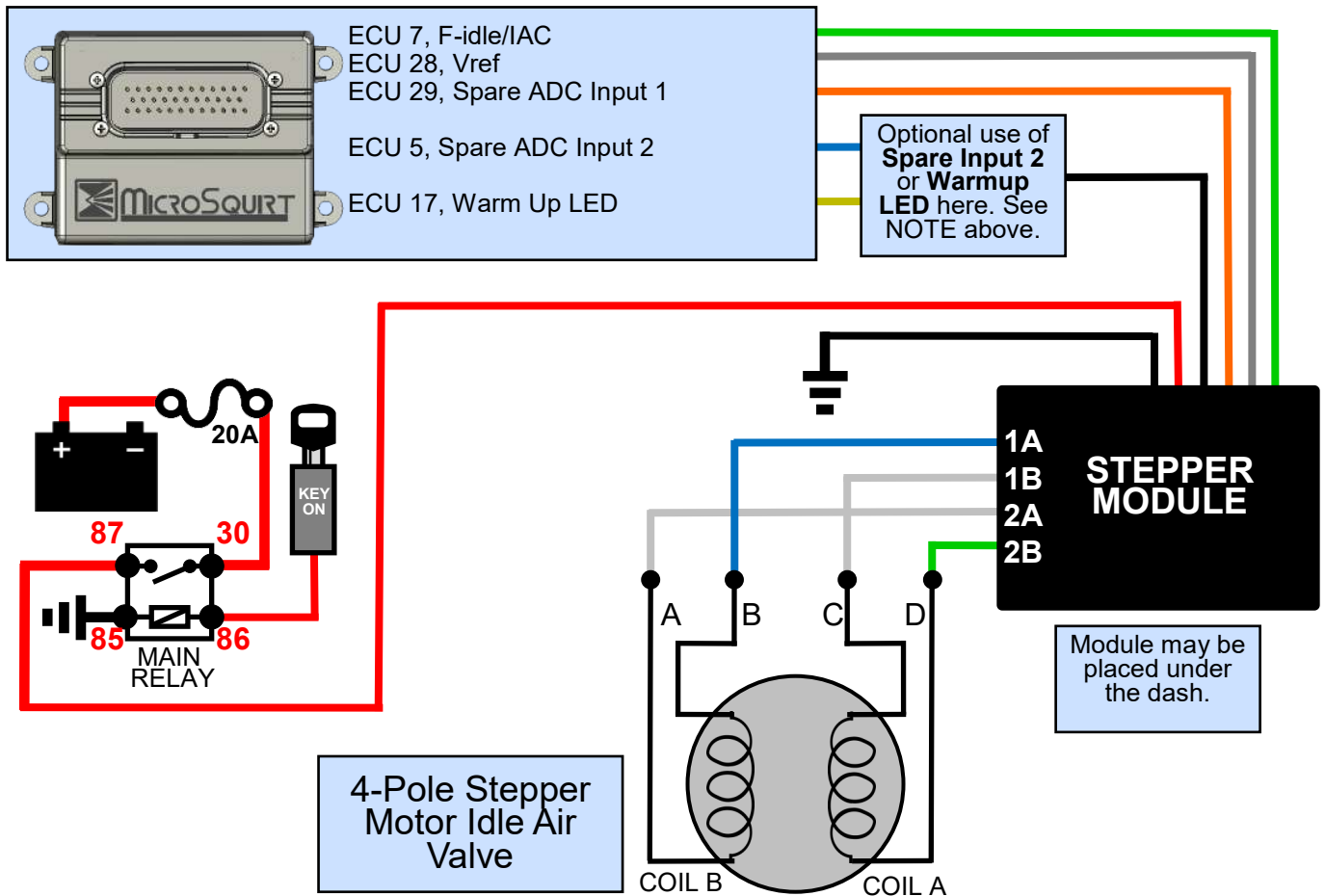

If you want to see an example of a 4-pole stepper motor idle air valve, one was used in this project page:

<https://www.240turbo.com/idleaircontrol.html>